

# HYBRID-ISM & MULTI-ETHNICITY



California College of the Arts, San Francisco, USA\*  
Accademia di Belle Arti, Palermo, Sicily, Italy

2018

FALL 2018

CCA

HIBRIDISM & MULTI-ETHNICITY

FALL 2018

# Hybrid-ism & Multi- Ethnicity

---

Fall 2018

# Hybrid-ism & Multi- Ethnicity

---

---

## Acknowledgement

I'm grateful to Professor Ivan Agnello for collaborating in this interdisciplinary Diversity Course "Hybrid-ism & Multi-Ethnicity", an exchange between California College of the Arts and Accademia di Belle Arti of Palermo and sustaining this opportunity for students interested in a fertile international dialog. Also, I would like to thank all the participating students from California College of the Arts and Accademia di Belle Arti willing to work on this project and make an effort to participate in a cross cultural conversation. A special thanks goes to Justin A. Joseph, Eugina K. Chun & Zita, Zixuan Yang, for designing this catalog and Mansour D. Alheera, for customizing and maintaining our precious class-blog, which is the platform for this international exchange and for making our class video for the exhibition in Palermo, Sicily, Italy.

---



## Table of Contents

---

Introduction	6-9
CCA Student Work	10-83
Mansour Alheera	12-17
Ying Ching	18-23
Eugina Chun	24-29
Ya-Hsin Chung	30-35
Zhiyi He	36-41
Siqi Hu	42-47
Justin Joseph	48-53
Minju Kim	54-59
Chen Ju Lei	60-65
Yuhan Luo	66-71
Siqi Iyu	72-77
Zixuan Yang	78-83
Palermo Student Work	84-129
Chiara Cumignano	88-93
Giulia Pagano	94-97
Giulia Fulvio	98-101
Chiara Sempreviva	102-105
Giula Terzo	106-109
Giuliana Barbano	110-115
Marzia Acquaro	116-117
Sara Carramusa	118-121
Serena Plano	122-123
Valentina Matranga	124-125
Valeria Gabriel	126-129

---



---

## Introduction

---



# Hybrid-ism & Multi-Ethnicity

---

**S.A. Professor Mariella Poli**



Immigration is central the cultural narrative of the United States, however, in the last decade the mass migration connected with a changing global economy and political unrest has increased immigrations impact. In 2010, the number of international migrants worldwide reached 214 million, or 3.1 percent of the world's population. The diverse cultural landscape within San Francisco continues to evolve, each new wave of immigration over generations both transform and are transformed through existing world communities creating hybrids of cultural identity or "Hybrid-ism".

The platform for the artworks on view in this catalog and exhibition are a result of an Interdisciplinary Course of Design and Art, "Hybrid-ism & Multi-Ethnicity" from the Diversity Program at the California College of the Arts, San Francisco, in an exchange with Accademia di Belle Arti, Palermo, Sicily, Italy. The idea of this exchange grew out of my yearly visits to Italy, where I observed rapidly increasing new multi-ethnic migration. Italy faces political questions

that reflect the pressures of modern globalization, economy, geopolitics, forced migration from neighboring countries such as the Middle East, North Africa and Sub-Saharan Africa. Areas and issues under examination include the representation of the multi-ethnic diversity mostly in under-privileged situations, with attention to the struggle and conservation of individual identity in a Hybrid landscape. This catalog and exhibition features the artworks from an interdisciplinary and culturally diverse group of artists/designers investigating current and historical dilemmas facing new immigrants as well as their influences on local and global culture in everyday life and their complex relationship to artistic and cultural production. Each body of work represents a unique perception according to each individual's experience, vision and culture identity.

The individual views in this catalogue and exhibition are a result of a complete commitment from each participant and their experience, vision, interests and esthetics.



---

**California College  
of the Arts**

Student Work

---

# Leftover Memories

---

## Mansour AlHeera



He is a film artist from the United Arab Emirates interested in digital media in relation to three-dimensional spaces and surfaces. A large part of Mansour's work focuses on the concept of adding elements of time and motion to static images and objects. His goal for the work is to reach a middle-eastern audience that don't see space for exploration in their own culture and religion, but more importantly, those who don't think they should or are allowed to do so.

Leftover Memories is an immersive video/audio projection installation. Simply described: On the floor lies a module of a human brain standing alone, but the brain itself is covered with tiny mirrors. The second and only other physical element of this installation is the projector that is projecting videos exactly on the pieces of mirrors covering the brain, and so then the images get reflected randomly based on where the light hits and how much of each frame is being shown which is dependent on the piece of mirror itself. The installation takes place in an empty room with white walls that act as the surface of viewing the visuals.

Unlike war/post-war art pieces that focus on death of those who have died, Leftover Memories focuses on the lives of those who have died, reminding the viewer that it's not only how and why they died is what should pull the focus, but also

just the fact that they are. Looking at today's politics, it is has become hard to believe that all lives are treated equally. As millions of West-Asian Arabs refugees forcibly escaped from their homes going West and North, it is disturbing to see how people and governments sitting far away from the refugees discussing the pros and cons of letting refugees in as if they are discussing a new bill; That was the inspiration for Leftover Memories. The videos projected will be showing clips from the daily lives of some of the people that died looking for a home. Again, not to affect our emotions by their death, but to remind us that behind those tears and suffering, they are people who not too long ago, getting a job or buying a car were examples of their problems; And to remind us that behind those tears, they are souls that have experienced joy like we did, and maybe even more at some point.

# Leftover Memories

video installation

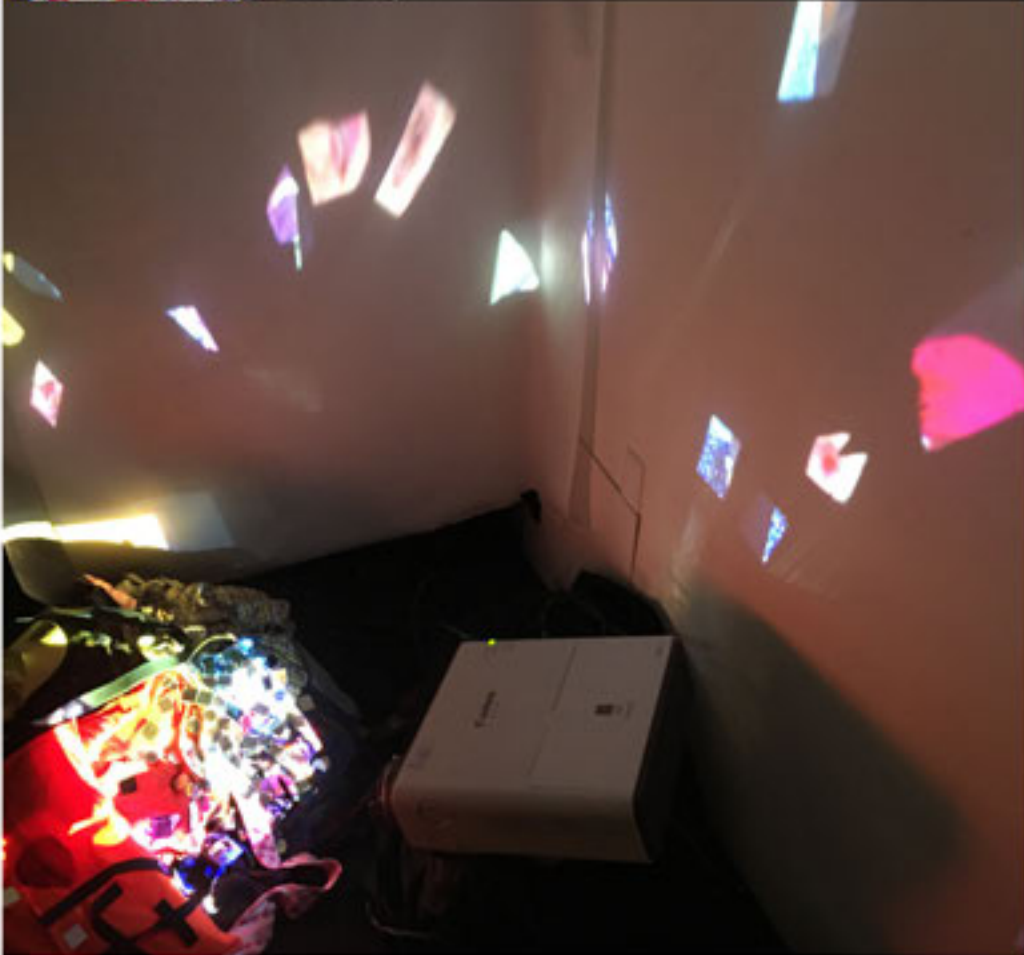



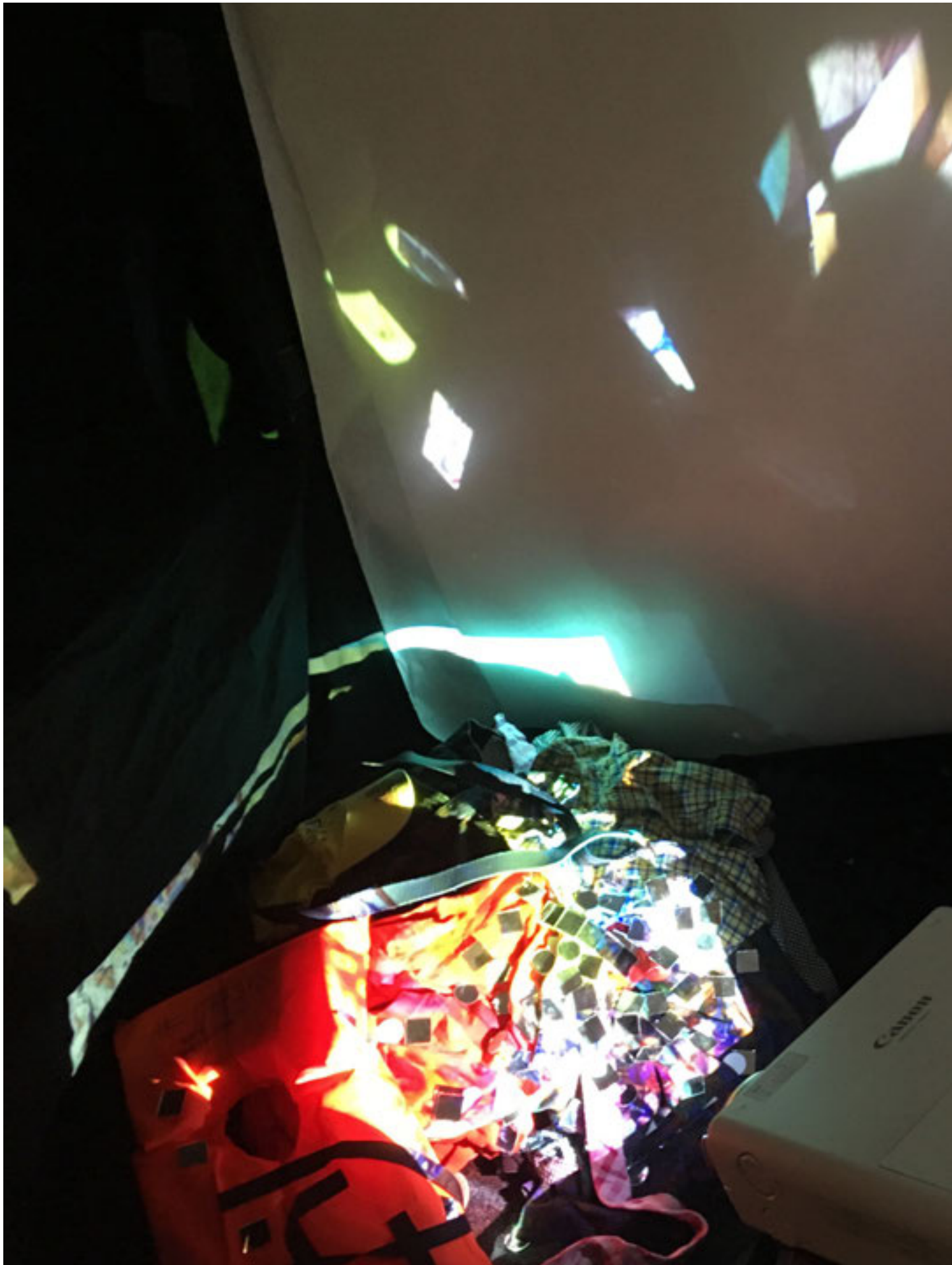

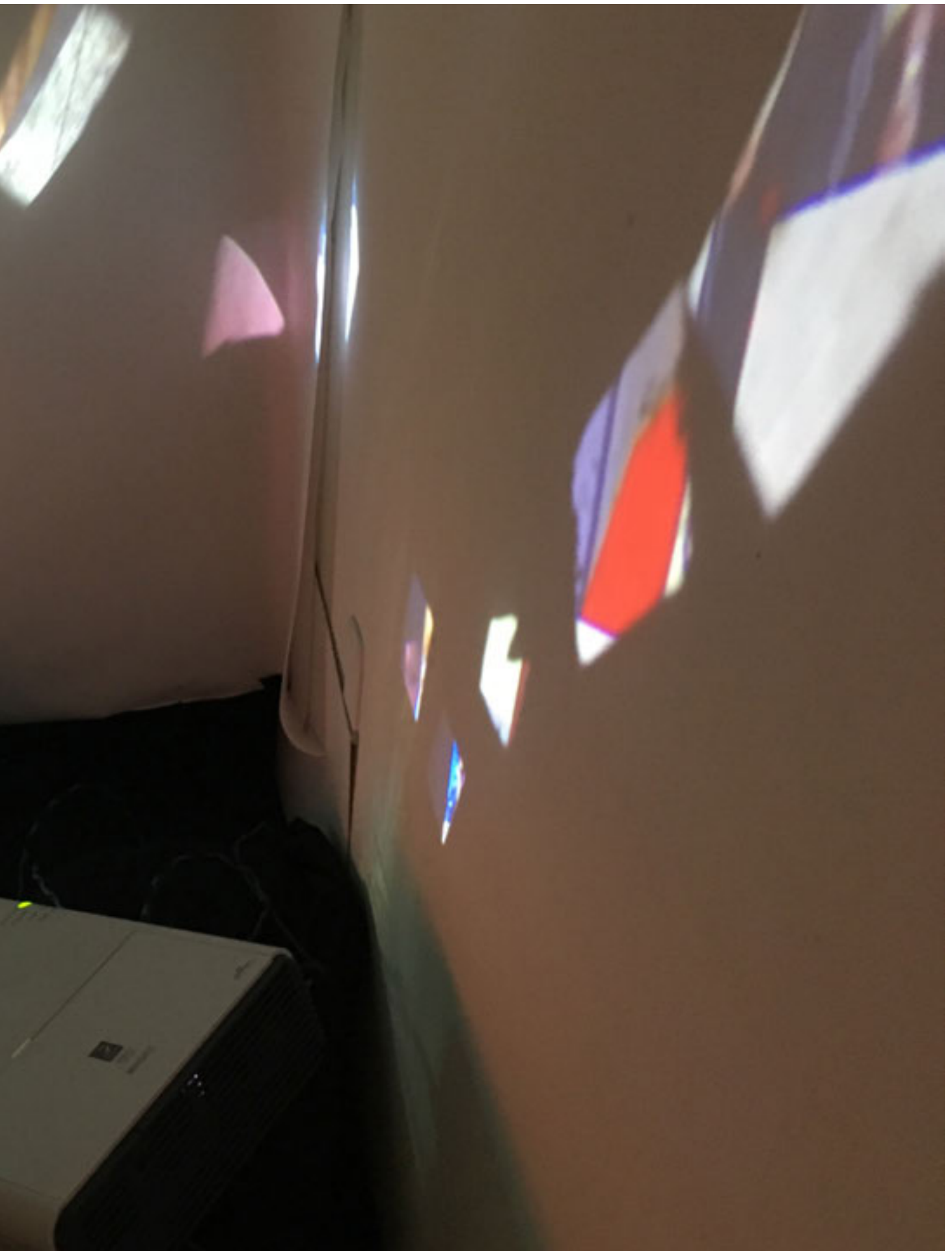

# HappyLand

---

## Ying Cheng



She is currently a senior interior design student at California College of the Arts, CCA. She is originally from Guangzhou, a modern city in south China. A big concept of most of her works is playful. She believes that fun is the magic method to change the world and design is a powerful tool to recreate the world, solving problems and provide a better life. She loves traveling and listening to music.

“Every happy memory created for a child is another treasure of a lifetime.” -- Donna Marie

Children are innocent and deserve a happy and carefree childhood no matter if they are refugees. Every time I read news or stories about how refugee kids are suffering from what they should not have suffered at their age, I feel really sorry and upset. I want to do something, something they can experience everyday, something protects their innocent childhood, and something can bring their smiles and laughter back after all of the difficulties they have gone through.

I want to redesign the playground of Refugee Transitions in Oakland, in an effort to provide the refugee kids a safe environment for entertainment. Refugee Transitions began in 1982 and their family engagement program was launched in Oakland three years ago. It encourages refugee families to participate together, while parents are taking English language classes, elementary school-aged children are

playing soccer, working on homework and preschoolers are engaged in early education programming. My hope is to build them a bridge which helps them to integrate to the local community. I want to provide them a platform where they can speak for themselves, tell their own story, gain friendship and prepare as much as possible for their beautiful future.

The goal for my project is to redesign the existing empty backyard into a multifunctional and playful space for refugee kids to learn about nature, have fun and make friends. There are a lot of potentials for this space, I don't only see the playground as a space for individual entertainment, more importantly, I see it functions as a practical social area which encourages kids to make friends. What's more, the playground can even become a platform open to the public, where it holds events to bring refugee kids and the neighborhood closer which in turn helps refugees integrate into the local community.



**“ Every happy memory created for a child i**

**Refugee Transitions, Oakland, CA**



**s another treasure of a lifetime.”**

**-- Donna Marie**



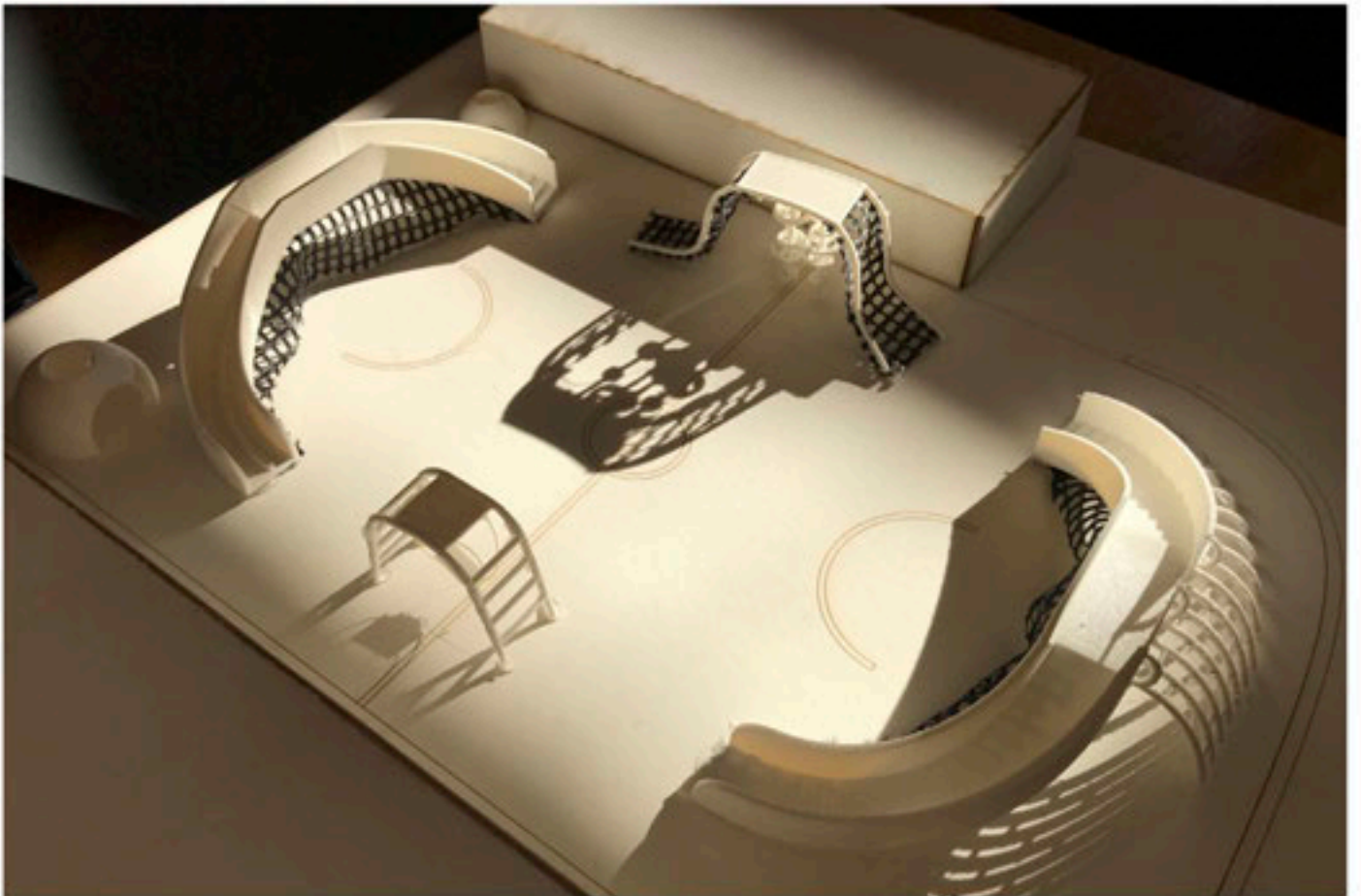
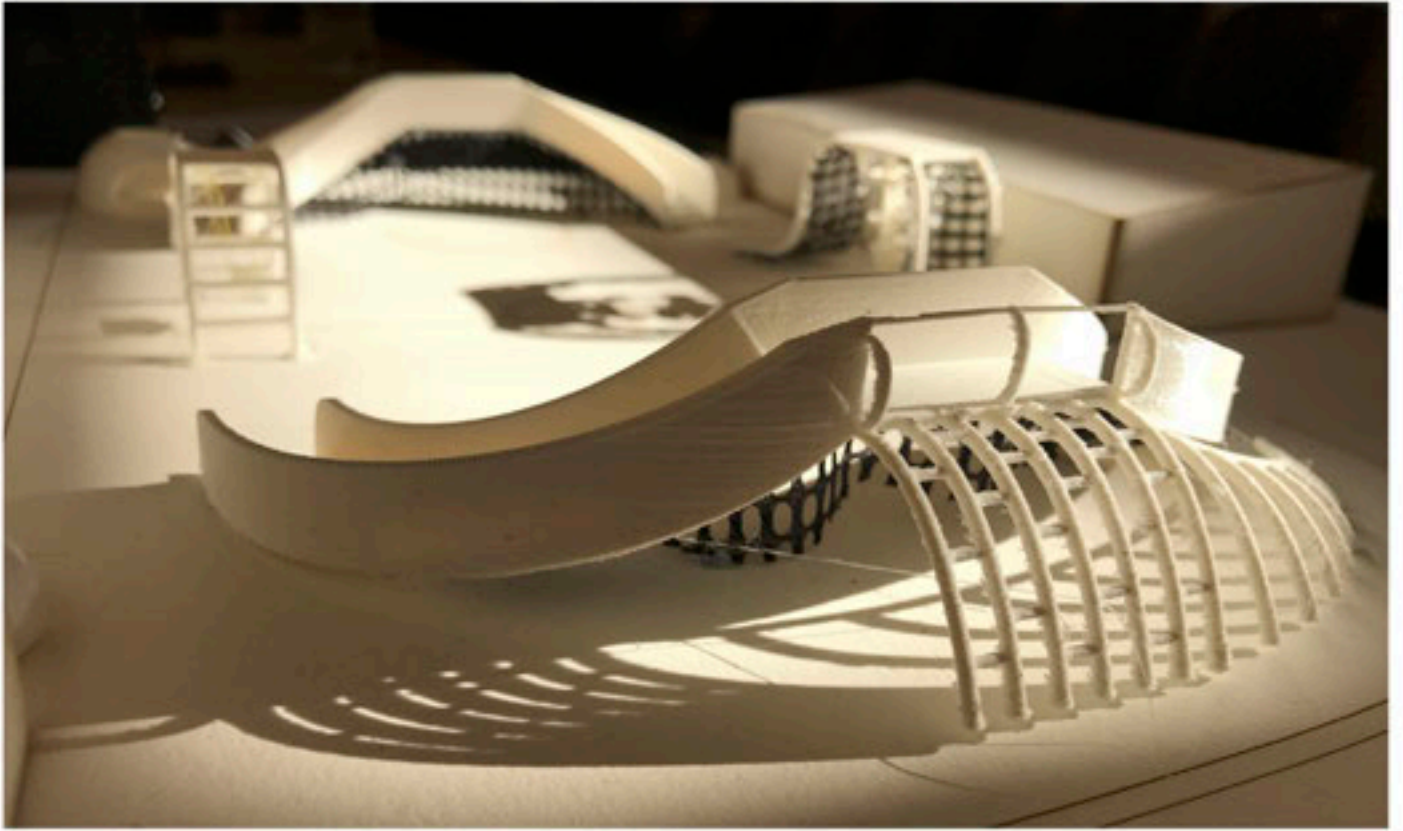

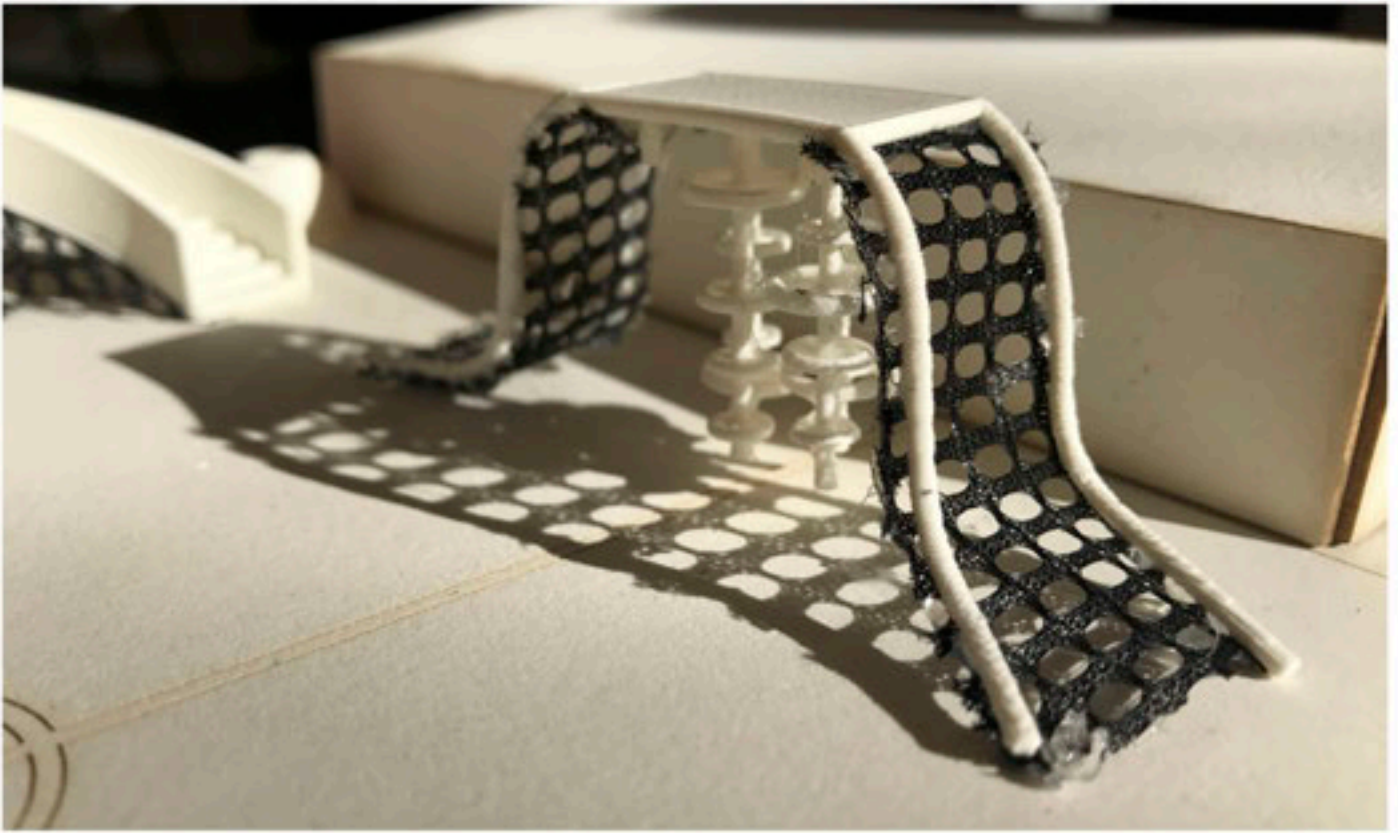

# Unheard Stories Told Through Instagram

---

## Eugina Chun



Eugina Chun is a Korean American artist studying Interaction Design at California College of the Arts in San Francisco. Born in Nashville, Tennessee, Chun's early adolescence and worldviews were simultaneously shaped in two very different yet similar cultural backgrounds. At age thirteen and alone, Chun left Korea to attend school in Pennsylvania where she discovered art as a means of self-expression when the English Language became a perception of self-restriction. Coming from a fine arts and animation background, Chun's medium-fluid design practice focuses on bringing together a sense of humanity, humility, and a cogent way of storytelling. Chun recognizes design as not only as an opportunity to solving pre-existing problems, but an opportunity to creatively, elegantly, and simply bring forth the invisible to visible.

---

As of June 2018, Instagram has reached 1 billion active monthly users.

According to a 2014 report, 68,541 unaccompanied minors entered through the southwestern United States border.

The minors are mainly from Central America where they risk their lives to escape extreme poverty and life-threatening gang violence. When the minors are captured at the border, many of them are put into solitary confinement in part of America's billion dollar industry. Once the minors turn 18 years old, they are directly transported to maximum security adult prisons. They have no family, friends, or people that care for them.

Isolated and alone, they have no way of having their story heard by others. The only thing they look forward to is a second chance in life - not a concert to attend this weekend, hanging out with friends, or school. Due to this reason, the minors go through a devastating and threatening experience during their fundamental developing stages of life.

When I re-encountered this piece of information in Hybridism & Multi-Ethnicity class taught my

Professor Mariella Poli, I was eager for other people to have access to the ongoing stories of minors. Other than news platforms, it is rare for the minors' personal stories to be told or even heard.

To decrease this gap of the minor's stories only existing on a specific platform to a specific group of audience, I wondered if social media could be used as another platform to document and tell someone else's story. I approached my project in belief that there is an opportunity to tell a compelling visual and verbal story of minors through one of the most active social media platforms, Instagram.

I put together images and stories from pre-existing news articles and reports. For the overall theme of the feed, I focused on developing a visual voice for sternness of the information and intimacy of the story.

In creating an Instagram page that focuses on telling stories of the unheard, unaccompanied, and undocumented minor, I hope to bring social as well as self-awareness in the social platform we exist today.





**unheardstories\_\_** Children attempt to reach the Mexico-US border by riding atop freight cars of La Bestia -- "the Beast" -- for hundreds of miles.

.

#unheardstories #unaccompaniedyouths  
#unaccompaniedminors #stories

.

Read more about this story:

<https://www.newsleader.com/story/news/2018/06/21/immigrant-children-asylum-america-border-journey-personal-risk-poetry/713330002/>

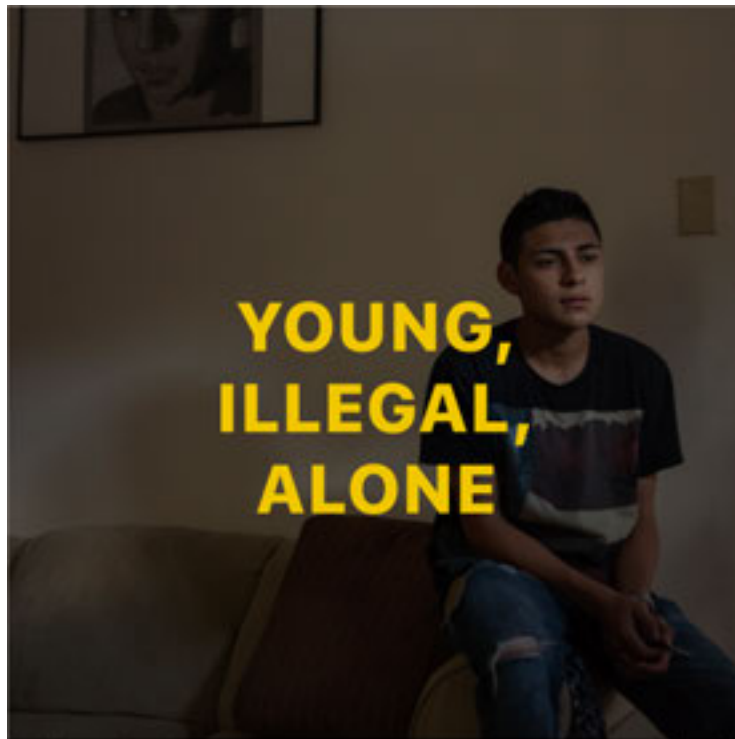

**unheardstories\_\_** Their parents sent them to the United States to escape brutal violence. But to stay, they need to convince courts that sending them here constituted child abuse.

One night last winter, Guillermo, then 15, walked outside with friends as it rained. He heard a car's tires slowing as it splashed through the puddles until it stopped beside him. A Barrio 18 gangster fired from the window. Guillermo ducked behind a parked truck; his friend leapt into a cardboard box. Guillermo and his friend were fine, but a young father who had stepped outside to make a call was shot in the stomach. The father ran across the street to a nearby hospital. He died the next day.

On July 1, 2014, Guillermo fled El Salvador. Almost 2,000 miles and a week later, he floated across the Rio Grande on an inflatable raft. When he arrived in the United States, he was one of 68,540 other unaccompanied minors to do so that year.

These unaccompanied minors overwhelmed an immigration system ill-equipped to handle them. They came to the United States to escape violence, but they rarely qualify as refugees: Children aren't an ethnic group, and gangs aren't granted the same recognition as invading armies. The U.S. does not provide these children lawyers, and that means most will be deported to the countries they fled. Unless, that is, they find someone willing, and with the knowledge, to help.

Read more about this story:

<https://www.theatlantic.com/politics/archive/2015/10/unaccompanied-minors-immigrants/410404/>



**unheardstories**\_\_ A group of immigrants from Honduras and El Salvador who crossed the US-Mexico border illegally are stopped in Texas.

Heavily armed street gangs such as the Mara Salvatrucha and Calle 18 impose a reign of terror on entire neighbourhoods across the region, which is also a key route for Mexican and Colombian cartels shipping narcotics north. .

Drug-fuelled corruption, political instability, and – in the case of Honduras, a rightwing coup – have all contributed to a situation of institutional collapse. As their states fall apart around them, many Central Americans feel that justice and security can only be found elsewhere. . “For many people the choice is to flee or to die,” says Carlos Paz, director of the San Pedro Sula office of the church organisation Cáritas. . .

[#unheardstories](#) [#unaccompaniedyouths](#)  
[#unaccompaniedminors](#) [#stories](#) . .

Read more about this story:

<https://www.theguardian.com/world/2014/jul/09/central-america-child-migrants-us-border-crisis>



15 posts 15 followers 0 following

Edit Profile

Unheard.Stories  
We aim to tell stories of undocumented minors.  
#unheardstories

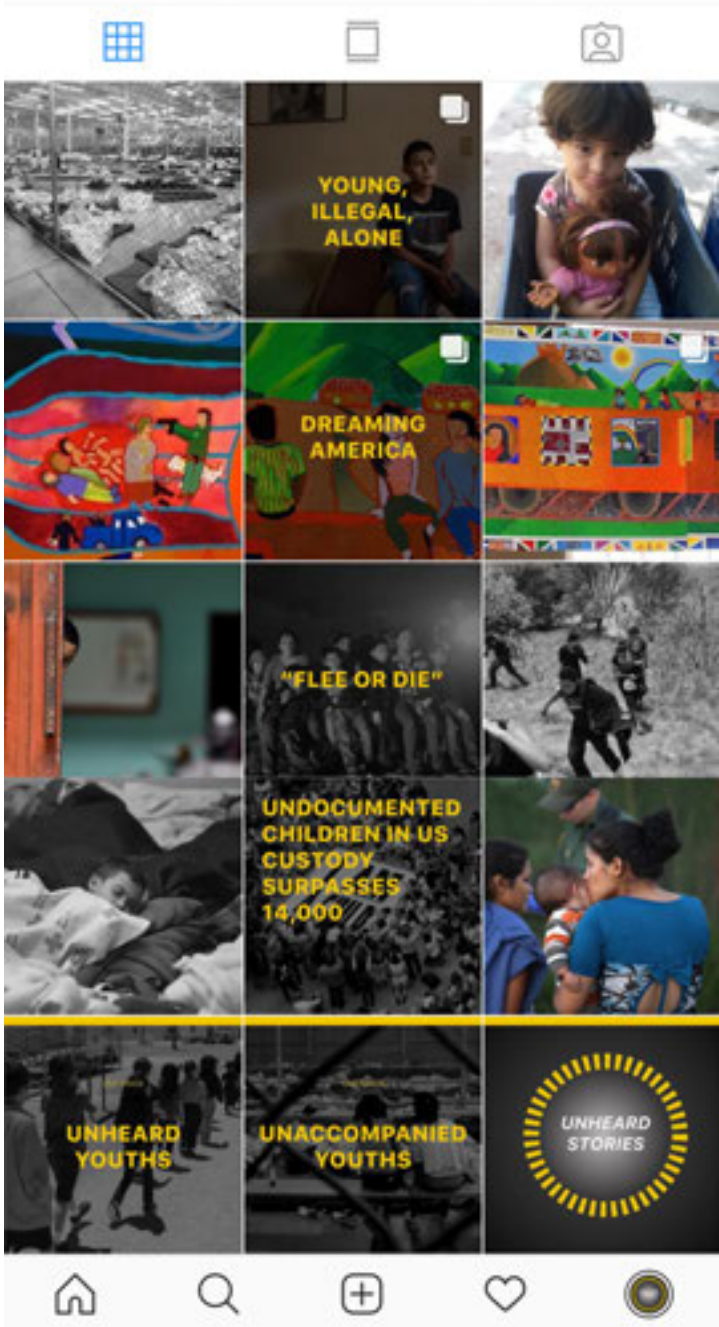

# Hidden Voice

---

## Ya-Hsin Chung



Ya Hsin Chung is a Taiwanese interior designer and artist currently studying in California College of the Arts. She is born in Taiwan, but she studied in an international school in Shanghai that really influenced her as an individual. The diverse culture that she has always been living in really influenced her interest in not specializing and her practice in actively engaging new things and ways of doing.

Tomorrow is not promised and today is too short, no one desires to live in fear and threat. Parents will do everything to protect their children and being a refugee is not a choice. Everyone seeks a place of safety and being with family makes us feel safe and sound. The family will always be our support and harbor of refuge when facing the cruel experience we encountered in daily living. I could never imagine what it will be like to be separated from my family. Therefore, I really feel sympathy for the unaccompanied alien

children that are separated from their family at the border and would like to raise awareness of the situation through this book I designed.

I believe effective help can only be achieved and provided when you have the full knowledge of the problem that you are trying to solve. Therefore, by collecting news and information from multiple sources I have brought to you “Hidden Voice” that is written in first person narrative that walks you through the thought and feeling of the unaccompanied alien children.

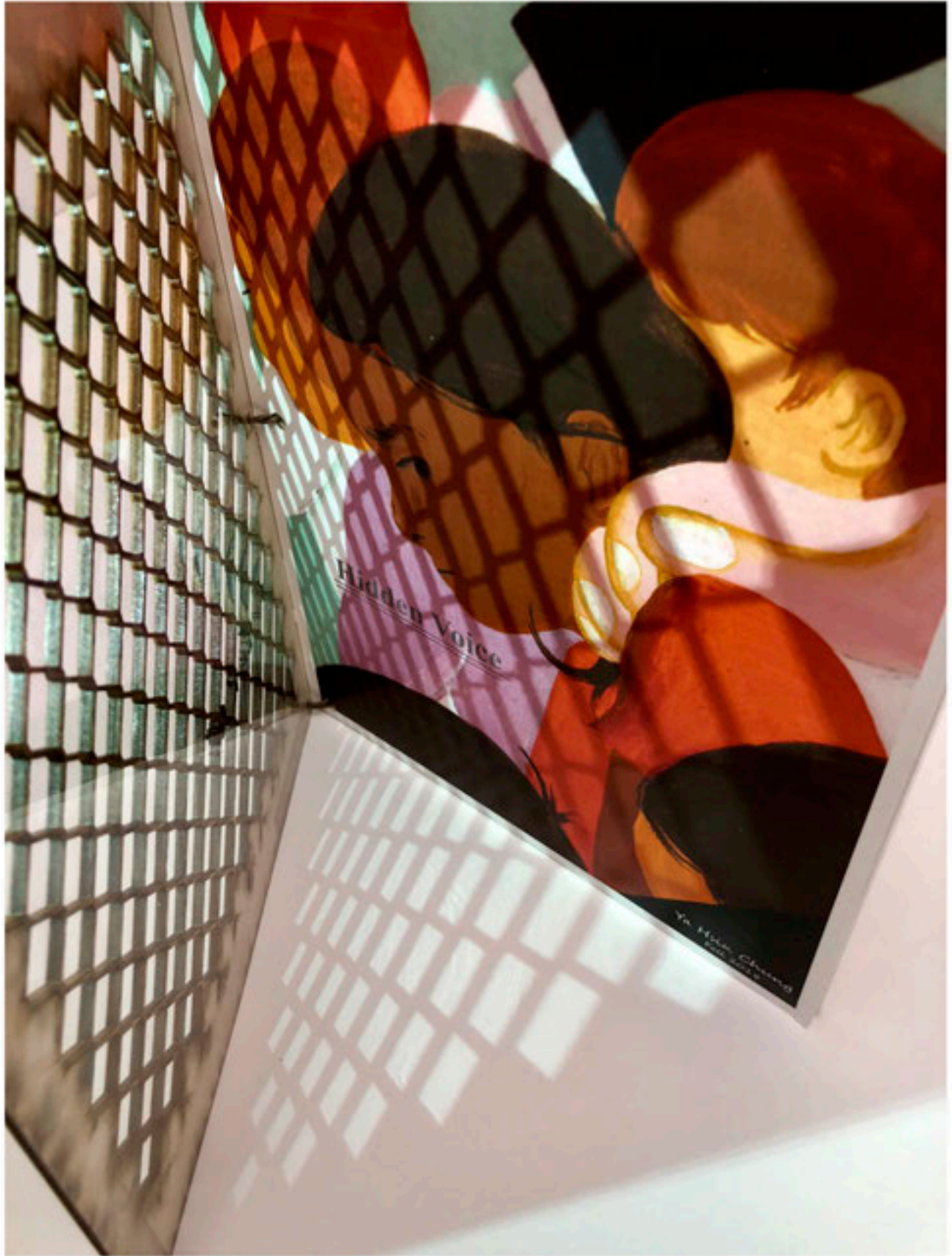

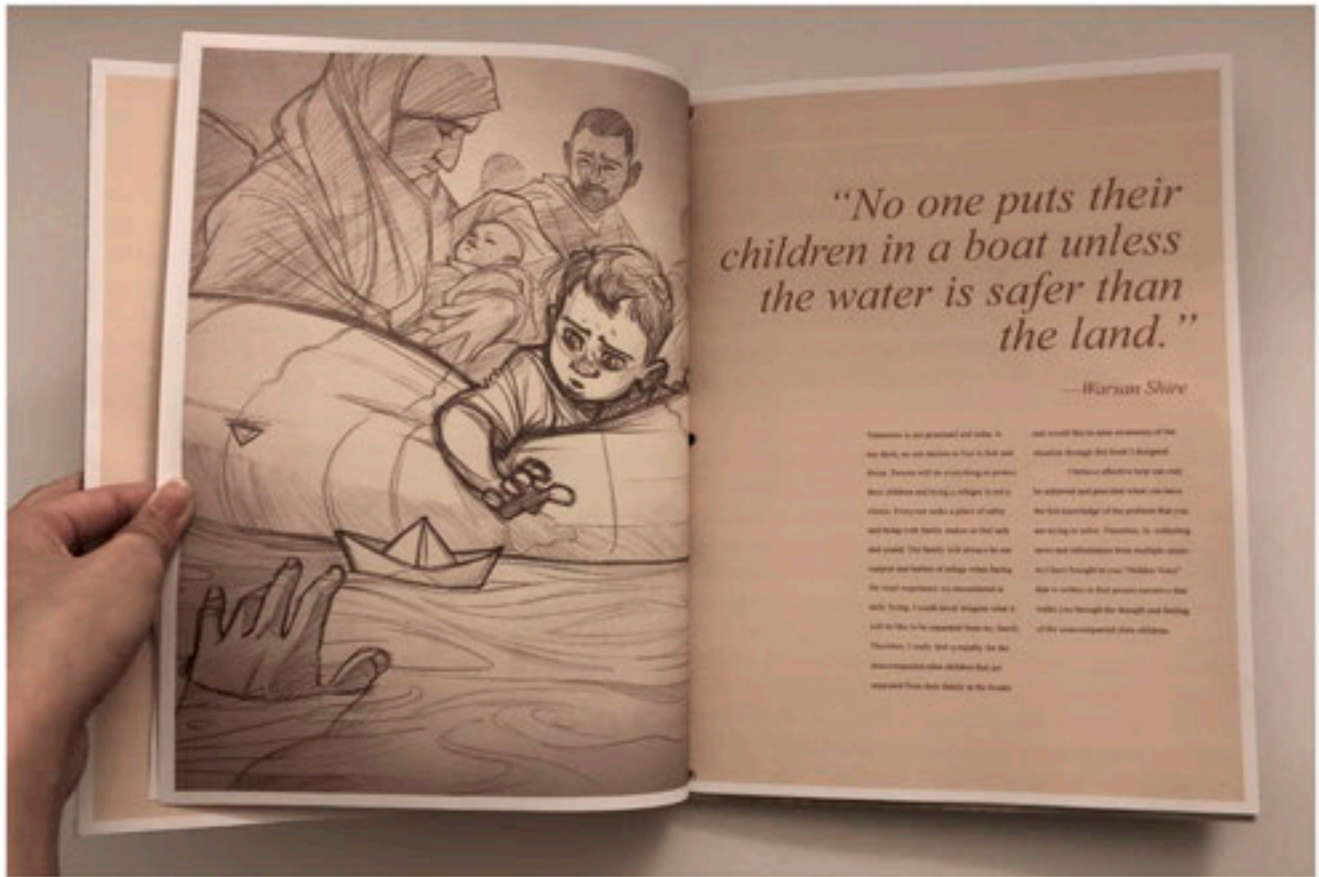

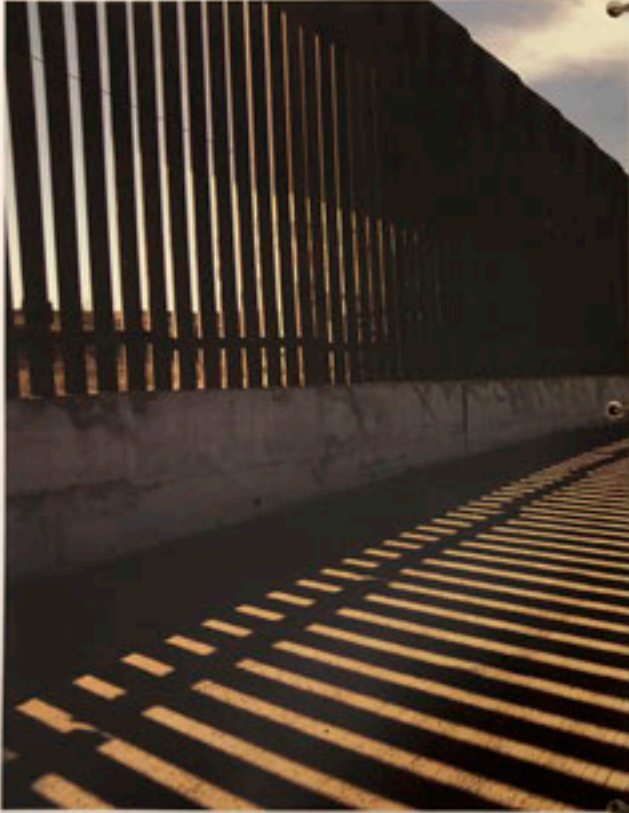

*"How wonderful it is that no one has to wait, but can start right now to gradually change the world! How wonderful it is that everyone, great and small, can immediately help bring about justice by giving of themselves"*

*—Anne Frank*



**Dear journal,**

Today is another "day" beginning when I look  
 surprised from my sister's brother to the brother  
 I opened my eyes and the first thing  
 that came into my sight is the white mattress  
 below of the bed I am currently lying on. Still  
 from the straight mattress nothing really but I  
 honestly, one of my better back in 2014  
 it is really, well, but the white mattress  
 never could be the. Why? It is because this is  
 the writing turned in 20 children that proved  
 best for the same reason, "writing the brother  
 myself"

I followed from the back that and  
 in that towards the entrance and just over the  
 opening door. The light-colored floor and  
 my own blue-colored in blue. For today, I  
 closed my eyes and I'm sure, there is no  
 amount of goodness can stand of historical fact  
 says this entire a sense of being. I am not  
 here, I guess at hand. The day, there is that with  
 white under the cloud. Reading, my dream  
 has finally come true. But because my brother  
 while the year? You can be without anything in  
 can dream of"



Dear journal,

Today is October 8 and I would like to share a story with you. There is a girl named Fernanda Jacquotin. Herita. She was the youngest child I can never imagine to be in the same situation as me, being separated from our family.

I actually found about her before seeing her. From what I overheard, Fernanda is only 2 years old. She arrived and was taken from her grandmother at the border in late July. And you will not believe I actually see her at the hotel city earlier in the day.



Before I see Fernanda, I actually see the big-haired man that is carrying her with a single hand. She was so tiny and seemed so naive that makes me mistake her as a delicate piece of doll held by the big-haired man at my first look at them.

understand me?", "Do you know why you are here?", "Do you have a lawyer?", "Do you know what is a lawyer?" My body operates a bit like the questions and the voice of the fearful judge sound in my mind.

I could not imagine how her feet would not from the heavy umbrella seat of the court. She must be too short to dangle from the seat. Importantly I can hardly imagine how she must have the court that I once faced with nothing but fear and worries for the same reason again, separated from family due to illegal crossing of the border. "How old are you?", "Do you speak Spanish?", "Can you



Unaccompanied alien children not only can't hire a court-appointed lawyer to defend them at court, many actually don't even understand the term "lawyer" & "law"



Holding the top of the desk and his knee are all representation of fear and nervousness...

## Acknowledgment

I'm grateful to the journalists that share and update the situation of the unaccompanied alien children and immigration policy of U.S. in time. Also, I would like to thank all the media platforms that give the journalists the opportunity to share what they gathered to the global bodies, both in forms of texts, images, and videos.

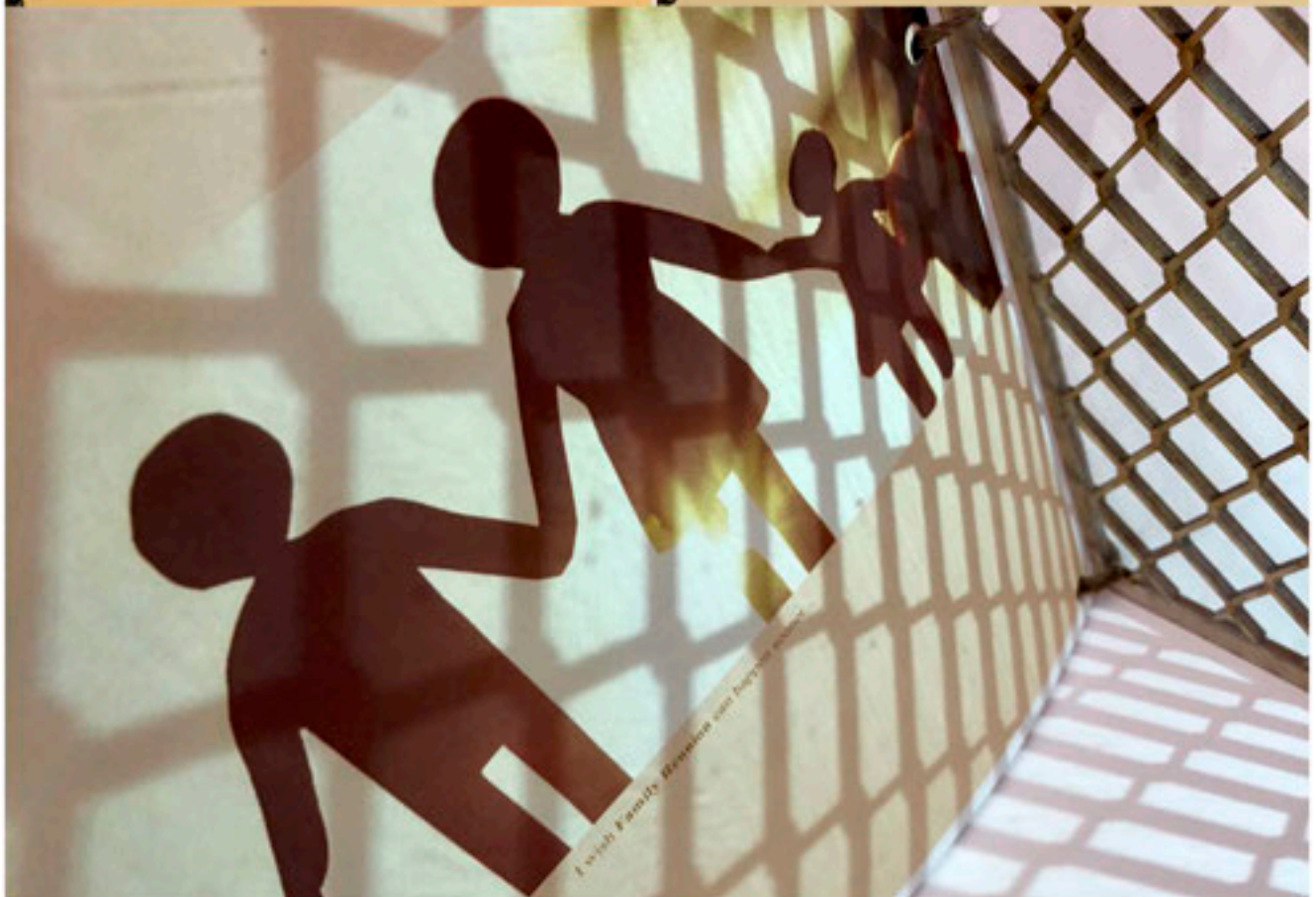

# Colorful Dream

---

**Zhiyi He**



She is currently a senior student in the BFA of Interior Design program at California College of the Arts. Design is a media for her to have a communication with the world. She believes that interior design can be a thoughtful response for a social problem, or an exposure of this progressive world. Her intention as an interior designer is to build better lives for more people.

By inspiring from the wellness project of Legal Services for Children and considering about the mental health of refugee children, this project is going to be a public and movable library designed for those kids to gather around.

The library will be open and friendly which does not have any doors or walls so that they can be free to get in there and have the sense of belonging. Lots of refugee children and illegal immigrants are not allowed to go to school. This project can provide them an educational opportunity.

The library will contain books in plenty of various languages like Mandarin Chinese, Thai, French, Spanish, Turkish, English and so on. From the conversation with Legal

Service of Children, most of the refugee children speak English and Spanish as their first language. So, most of books in the collection are English or Spanish version.

This project is designed for children at different age range. Book categories are various from age 0 to age 21. Furthermore, the shelf is designed with different height and some of them are adjustable.

The location of this project is at the activity space of the organization called legal service for Children that I am working with. All of those books are donated or secondary used and also can be checked out.



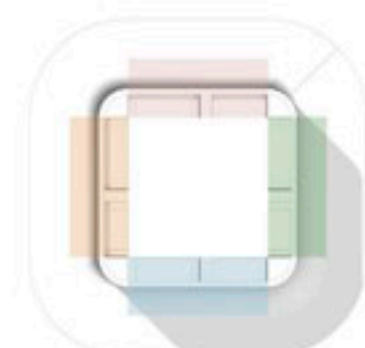
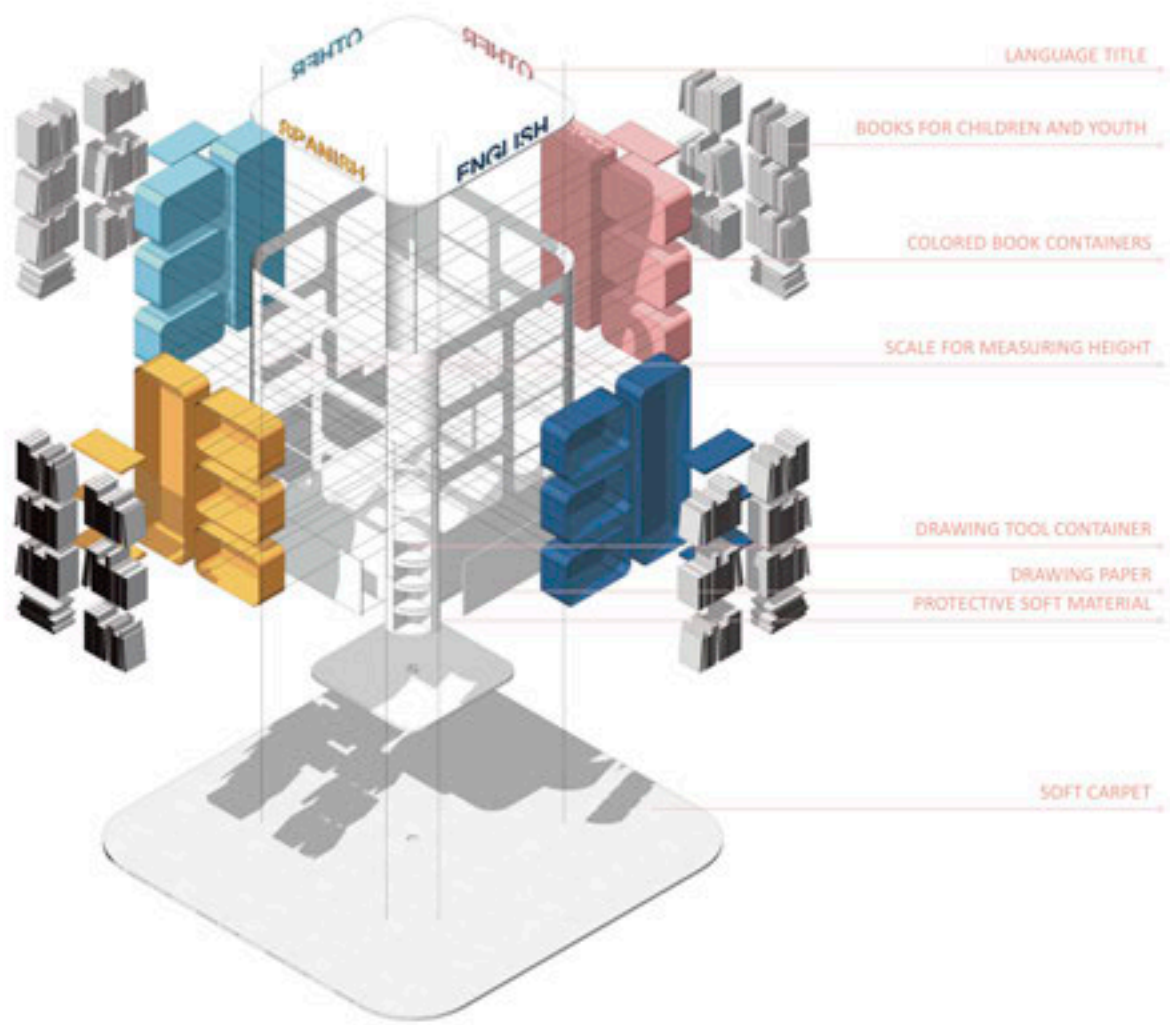







# Muti-communicated Hub

---

**Siqi Hu**



Eve is currently a Senior interior design student at California college of the arts. She loves jazz and horror movie. She is originally from China. As an interior designer, she expertise in form exploration and interested in multifunctional space. She likes to experience with material , light, and space creatively.

This project is inspired by the wellness project of Legal services of children (LSC). LSC is a non-profit law office which provides direct legal and social services to San Francisco Bay Area children and youth since 1975. Basic on the goal and clients of Legal service of children, there are several problems need to be solved through the research process: There is a small therapy room in the organization. Now it has a quite tall ceiling and narrow space with no soundproof. It is not a private space at all especially when someone is talking outside, people who inside of the room can hear the voice. Both of the sofa and lighting facilities are old and worn out a lot.

Children are hoping to spend their time working with LSC is designed to be therapeutic. Most children do not have a particularly

clear understanding of the law. My primary purpose is to improve the therapy room into an acoustic space with the unique look and designed for the children to evoke imagination and feel relaxing when they are entering space. Also, create multiple activities area for children to learn more information.

The tray table and the seats inside of the room are designed to be movable and rotatable. There are two layers of acoustic wool panels to keep the soundproof from outside to the inside of the space. The children who used this room have specific emotional or sensory needs, so the color of the room is designed to be neutral.



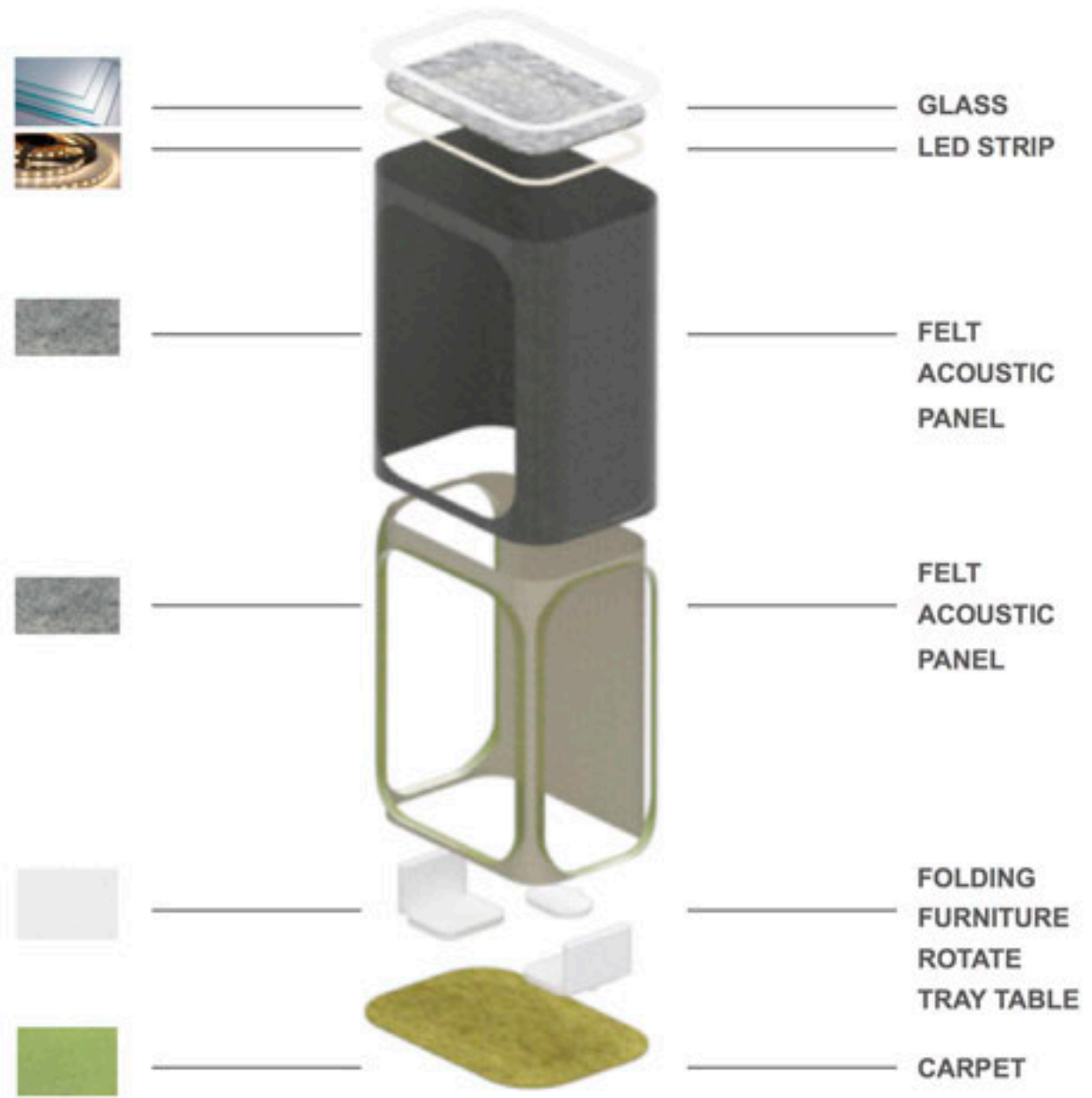

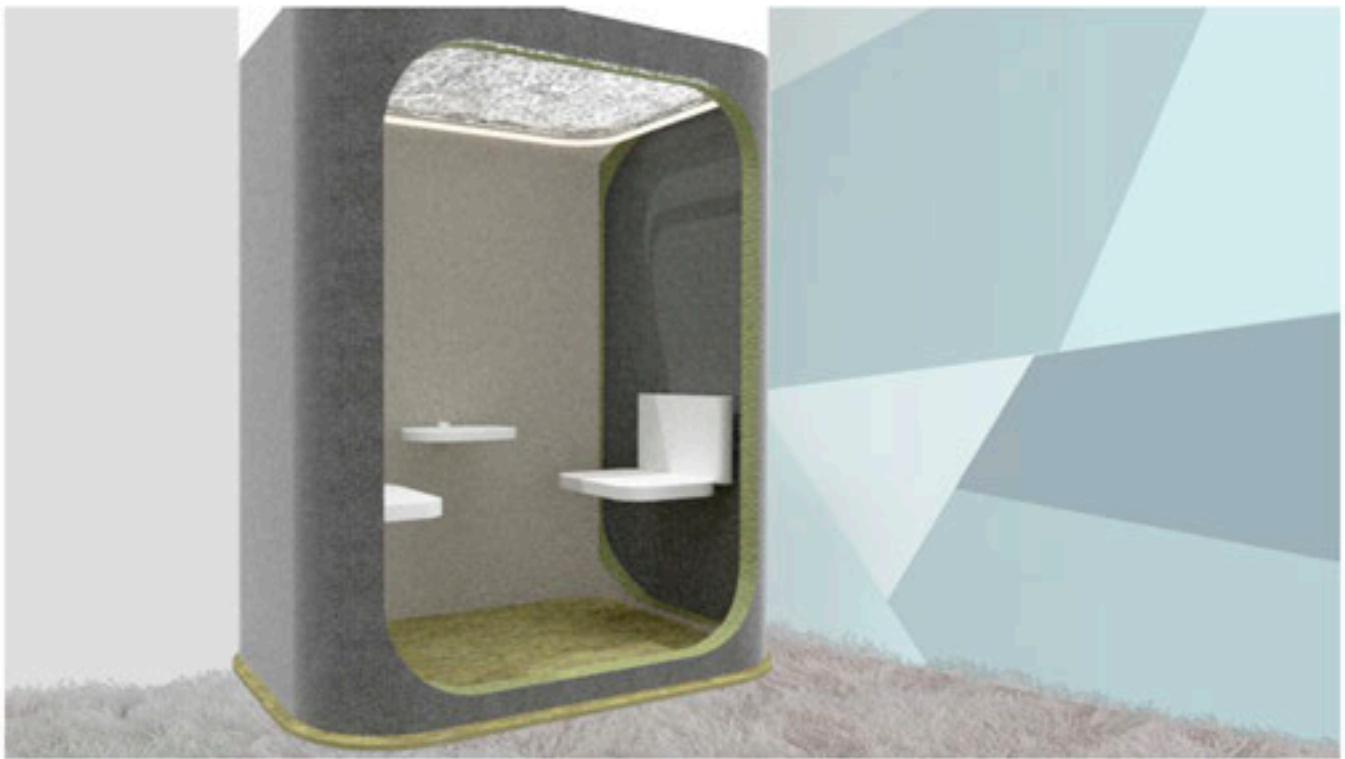
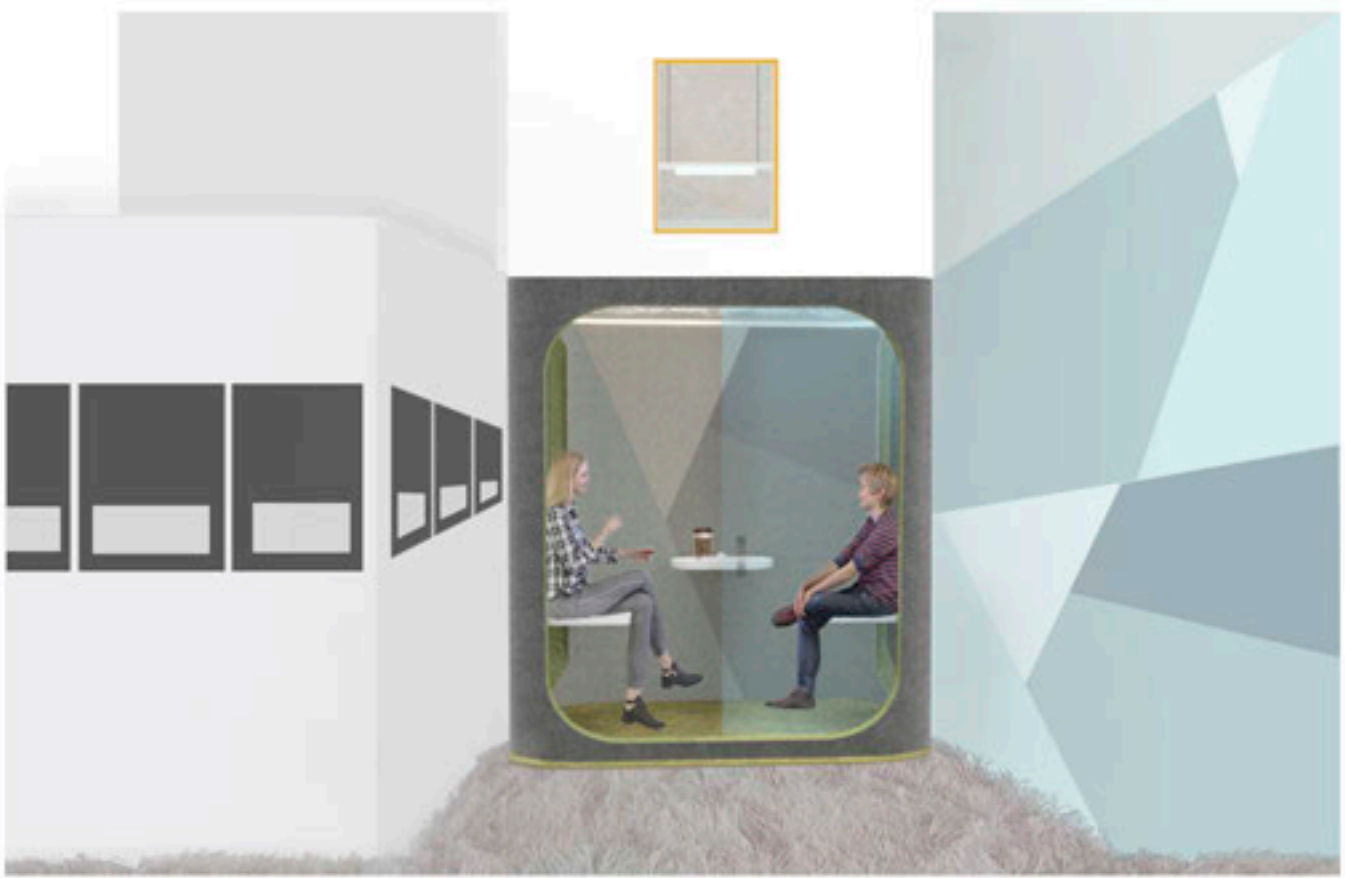





# We Are All Dreamers

---

## Justin Joseph



Justin Joseph is currently working on his BFA in Photography at California College of the Arts. Born in Los Angeles, Justin has been inspired to create since a very young age. Inspired by light, colors and form, his work uses these ideas to compose his images. Some activities that inspire Justin's work is seeing live music, being out in nature, collaborating with friends and seeing gallery shows of artists working in different mediums to name a few. This semester his work is taking a political route within his diversity studio class, Hybridism and Multi Ethnicity, where he is using his graphic design background to make a series of posters speaking about undocumented minors.

---

In these twelve graphic posters, *We Are All Dreamers*, I am responding to what I have learned this semester either in class or from what I researched on my own about unaccompanied minors and DACA. Childhood innocence is being taken away as they are torn apart from their families and kept in facilities that are overpopulated with people. There is a constant fear of the possibility of being deported back to a country of violence and crime. The United States is reverting back to a dark time in history where immoral action and unjust treatment towards an "unwelcome" group of people is occurring. I am reflecting on these issues and in many posters, there is a hidden or symbolic meaning. I am leaving the posters in dialogue with each other with the idea of creating your own narrative or meaning when looking at them as a series. Some posters have a straightforward approach but can build connections with the surrounding graphics.

This is a time where violence, crime, and hate are at an all-time high and people need the chance to escape it. Many people don't have a home to go to because their family was either murdered or

living in the United States. There is so much funding that goes towards keeping these borders protected from so-called outsiders. There is funding that goes to keep the camps running for unaccompanied minors but why not use that money towards helping them get to their families or out of harms way instead of creating a miserable situation for everyone involved. In a perfect world, this work would be seen in street view and would be triple the size with the ability to see them in the distance. Do people really know what is happening with undocumented minors? Some people believe that these children lucky and are given the proper treatment living in these camps. It isn't nice to be separated from your family and it isn't nice to be living in crowded spaces. Hopefully, people are able to understand that Mexican and Central American immigrants need the help to survive and live a fruitful life.

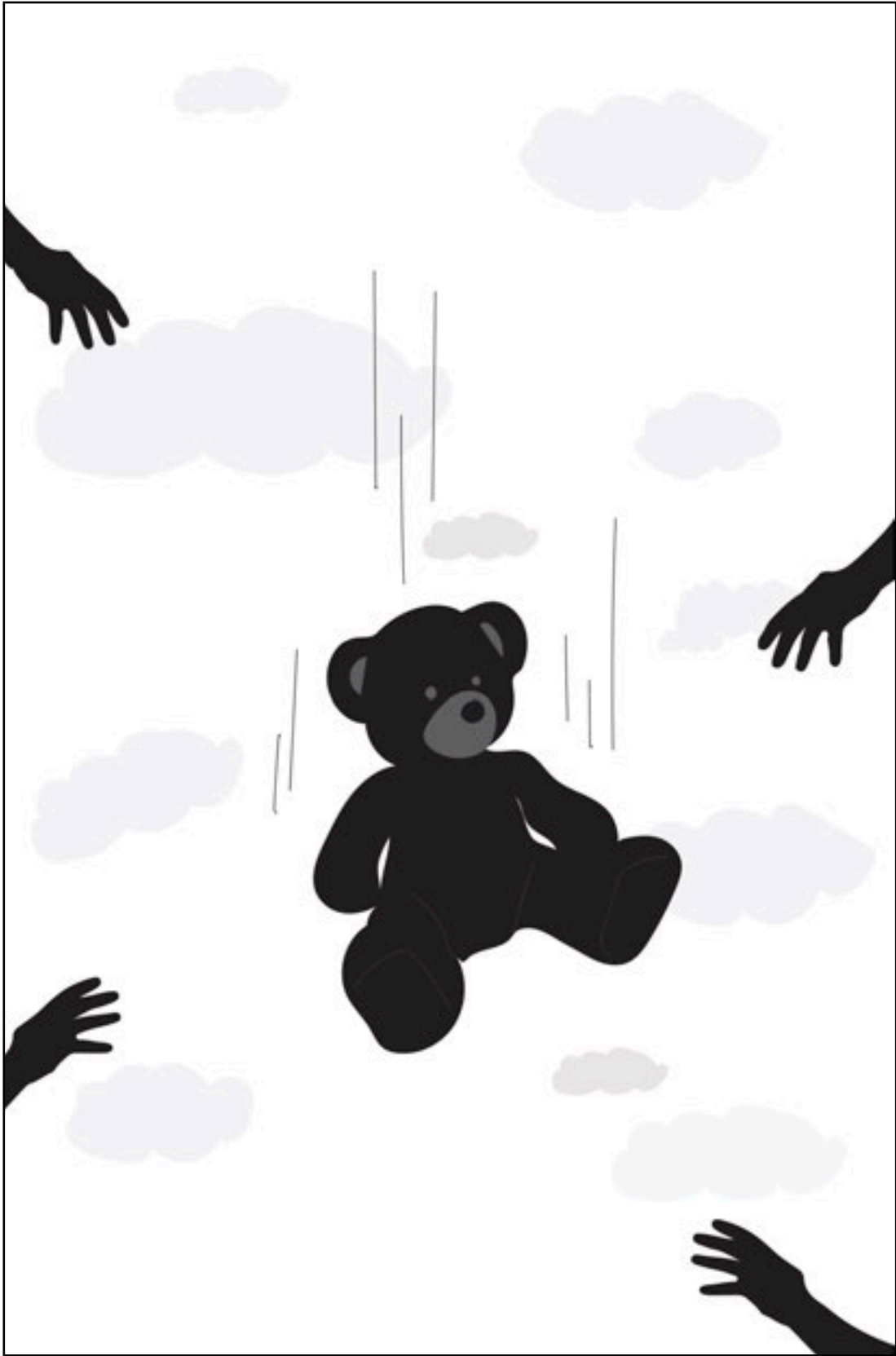





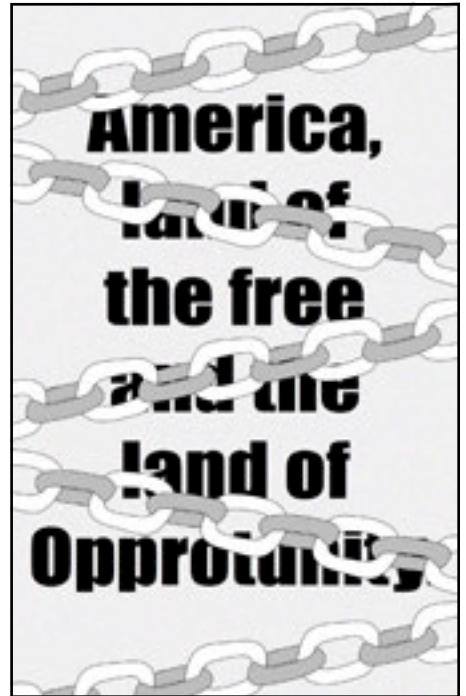
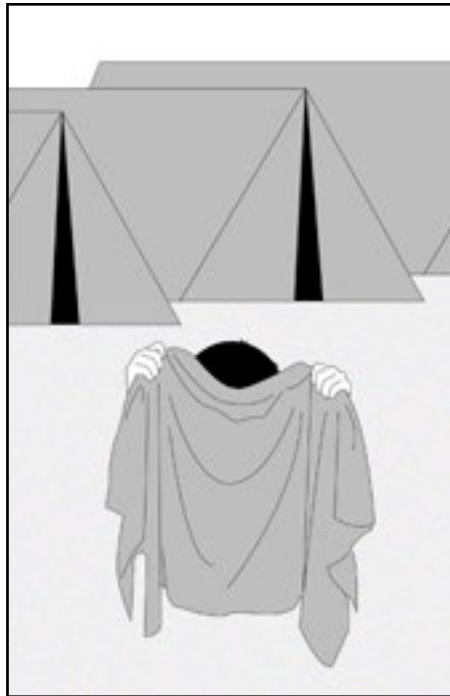

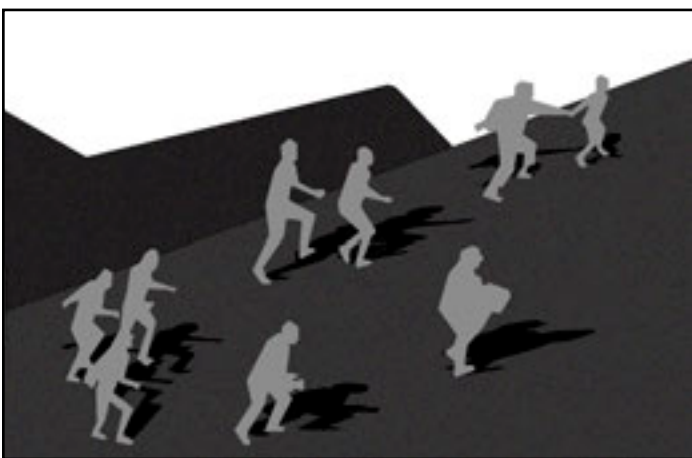

There are more undocumented immigrants in the United States than the amount of dots on this page.

# Hex a pod

---

## Minju Kim



MinJu Kim is studying Interior design at California College of the Arts. She has moved multiple times from Korea to Miami Florida to Atlanta Georgia. Atlanta Georgia is mainly where she grew up and where she was open to diversity. Minju designs spaces by exploring people and their individuality. By listening to their stories, she wants the space to reflect who they are and what they believe in. Not only will this create comfortable space, but also unique designs that will stand out among others.

---

When I sleep at night I'm comfortable, warm and safe. It's never too hot or too cold. When it comes to refugees and immigrants they struggle every night to sleep. Not only do they struggle to sleep but they don't have a space to feel safe in when they are separated from their parents. My design concept of the sleeping pods is a way for the children to have their own personal space but also feel safe. These children right now are placed in a cubicle separated by a piece of cloth with bunk beds. The space is small and crammed with no safety and open to the heat. They have poor health issues and mental issues and the refugee camps disregard those them. The space the children are surrounded in are important to

their mental and health issues. This is why I want created a safe environment allowing them to have privacy but also a community.

The sleeping pods are also a way to create a community for the children to gather and have a space to talk and create friendships among each other. It also saves place because the pods are stackable allowing more pods to be placed for all the children. The pods create safety by having its own personal door and creating comfort by placing shelves and storage for them to store their personal items.









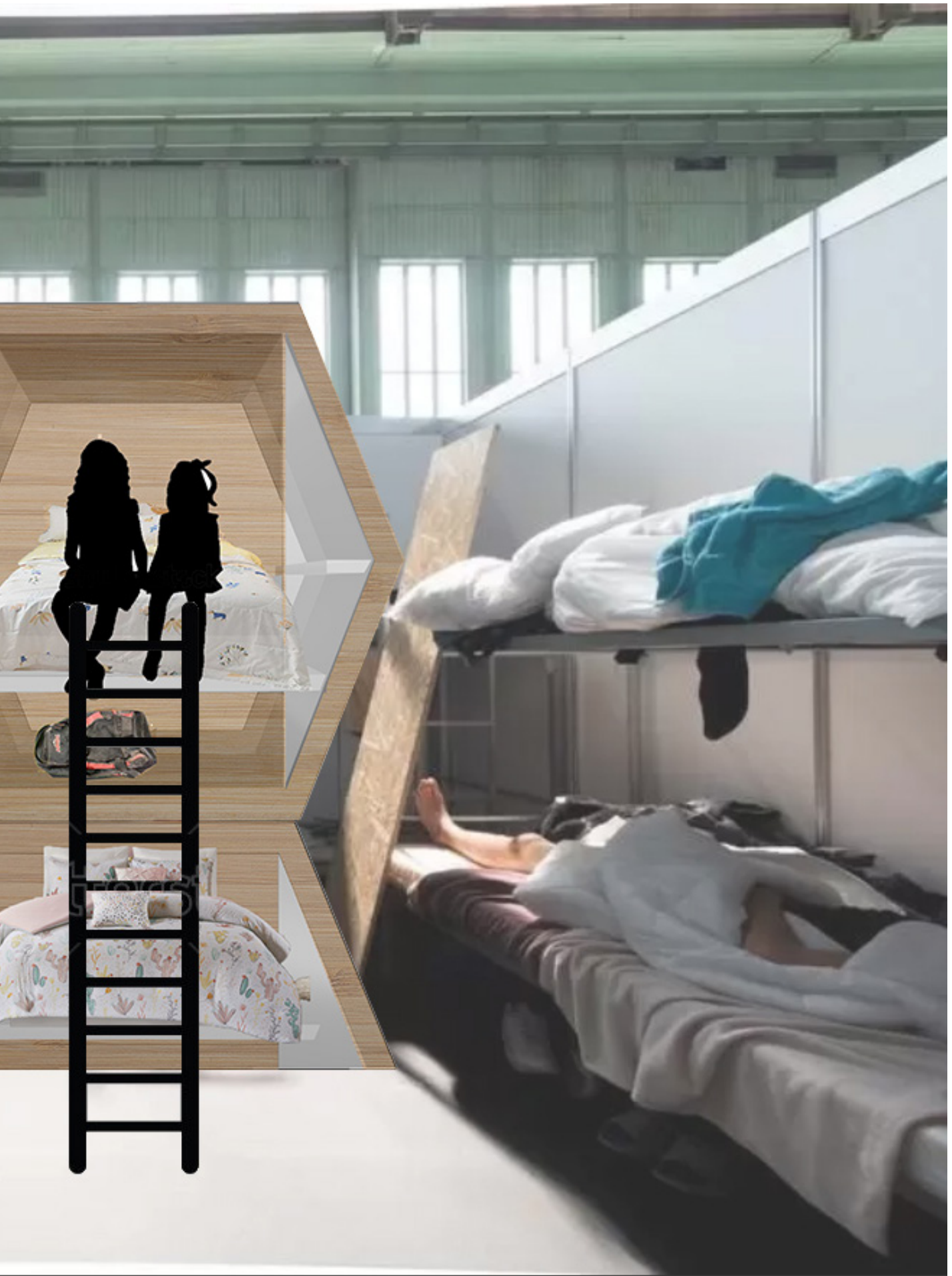

# Border Wall Memorial

---

**Chen Ju Lei**

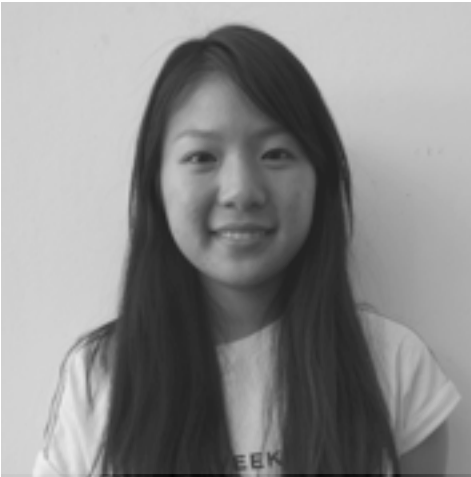

Jenny is a senior majoring in interior design at California College of the Arts in San Francisco. Living and traveling in multiple countries such as Mexico, Taiwan, and Singapore, has given her a wide intercultural perspective which allows her to be open-minded with sophisticated sense of style. She always love to challenge herself and produce innovative and creative work at every scale.

The Border Wall Memorial attempts to raise the awareness on the number of deaths at the border recorded each year. I have connected with the leaders of the Border Angels, who are organizers of the Border Water Drop Event, to collaborate with me to create this project. They provided many data and information about the death rates at the border. We collaborated to design the memorial to not only be aestheti-

cally beautiful but also impactful. The memorial is designed chronologically rather than alphabetically to express the idea of journey in time. Plaster and granite were suggested to be used for the project because we wanted our project to be sustainable and environmentally friendly. The wall also acts as a protest installation against Trump's border wall.









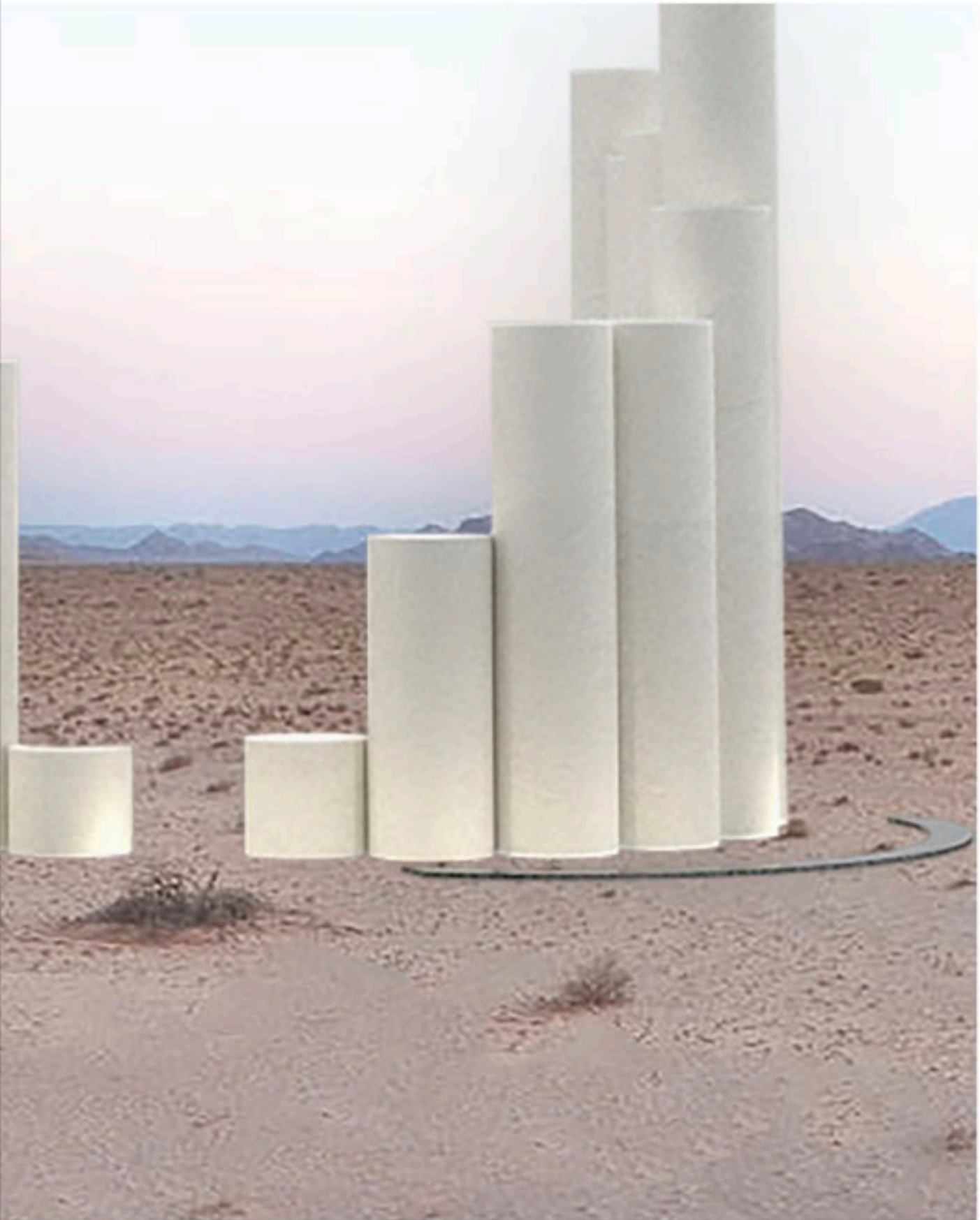

# An Origami Home

---

**Yuhan Luo**

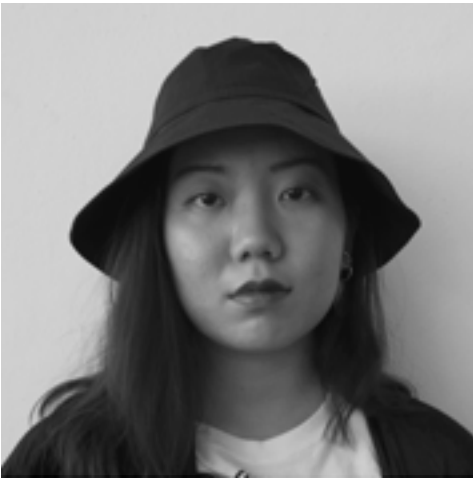

She is a junior majoring in Interior Design at California College of the Arts (CCA). Over the last two years in college, she knows more about the meaning of design and how she can improve herself. For her, Interior design has the power to organize the space and can't be represented in one form. Interior design for her is a way to view the space around everyone in a different way. She enjoys working together with the space, along with air, light and sound.

---

This project is designed for those people who stay on the border waiting for a chance to get access to the country. And it can also built for those unaccompanied children because this project provide a relative private space for one child. The concept of this project are Origami and Intermodal Container. Origami is the art of paper folding, many designers use this technique in architecture and sculpture in their projects. There are many examples to find, so I also want to apply this technique to my project because it can be really flat when it was folded but created the space when it stretch in directions. There are also many examples that a series of Intermodal Container can formed to be a architecture. A single

Container can also provided a place for single one to live.

For the two big ideas, I want this project to be really easy to transport and even carry by people so that they will not be worry about just stay the whole night in a unsafe space. Also, I think the project can provide a better arrangement on the border because I think the border agents also have the responsibility to take care of the people on the border. This project should be functional both in interior and outdoor.





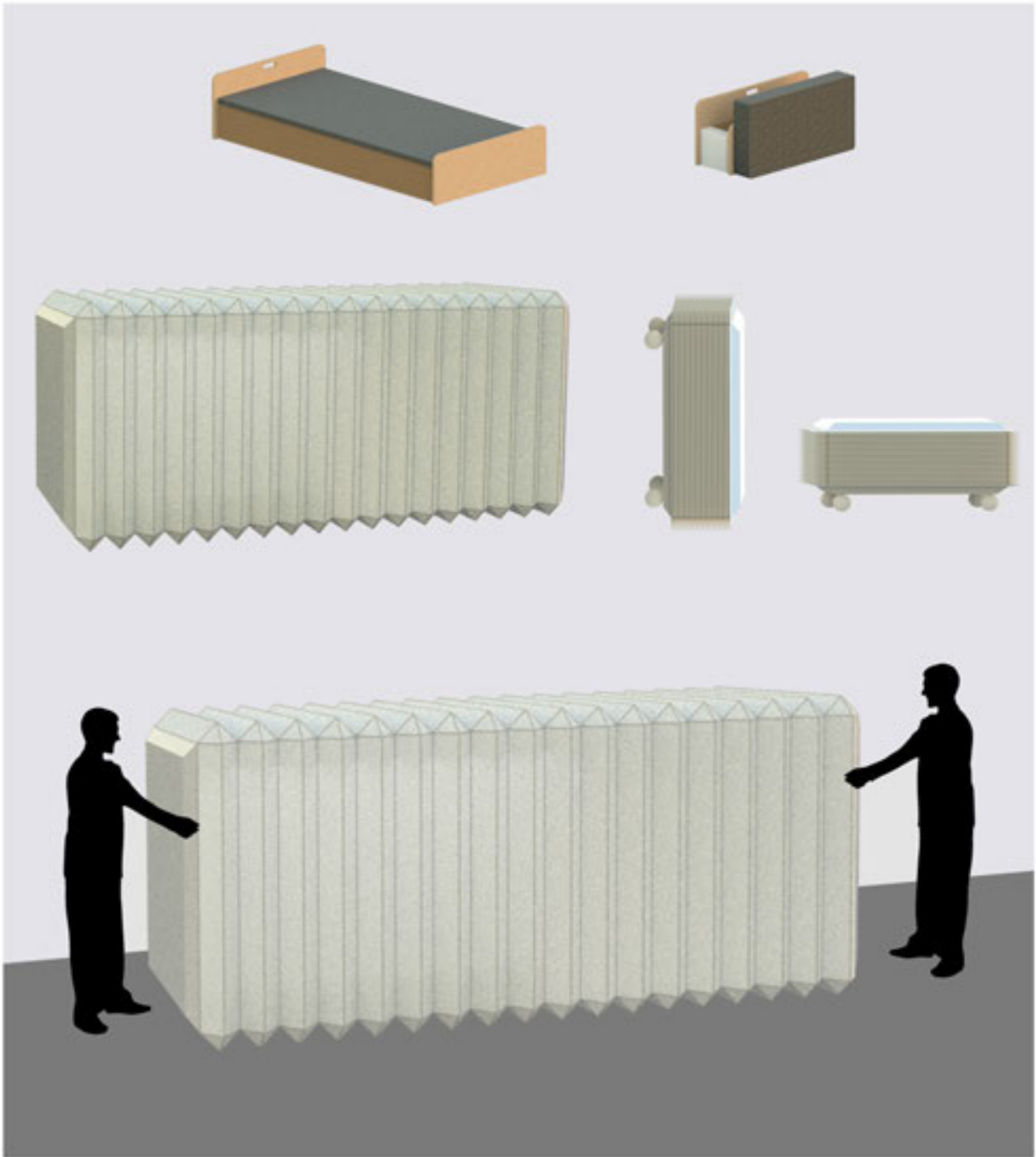

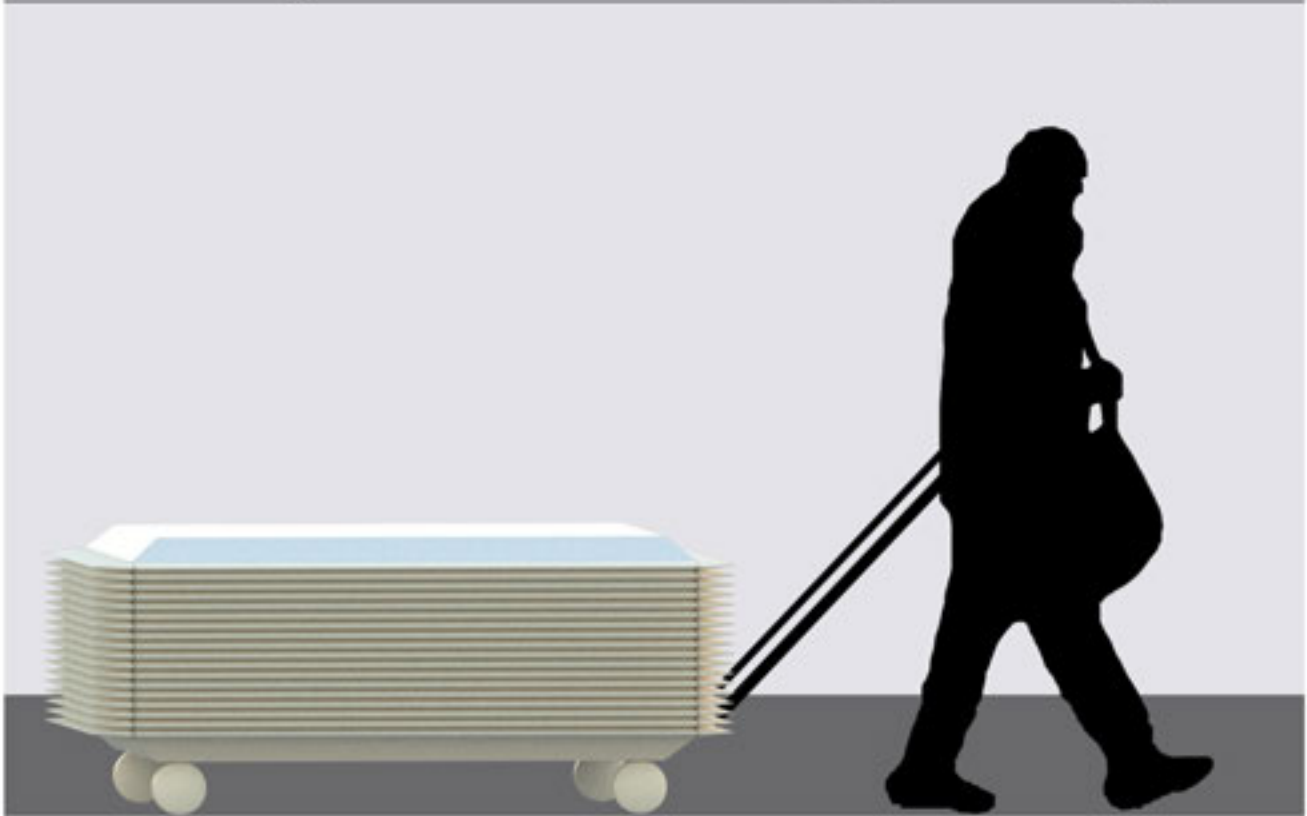
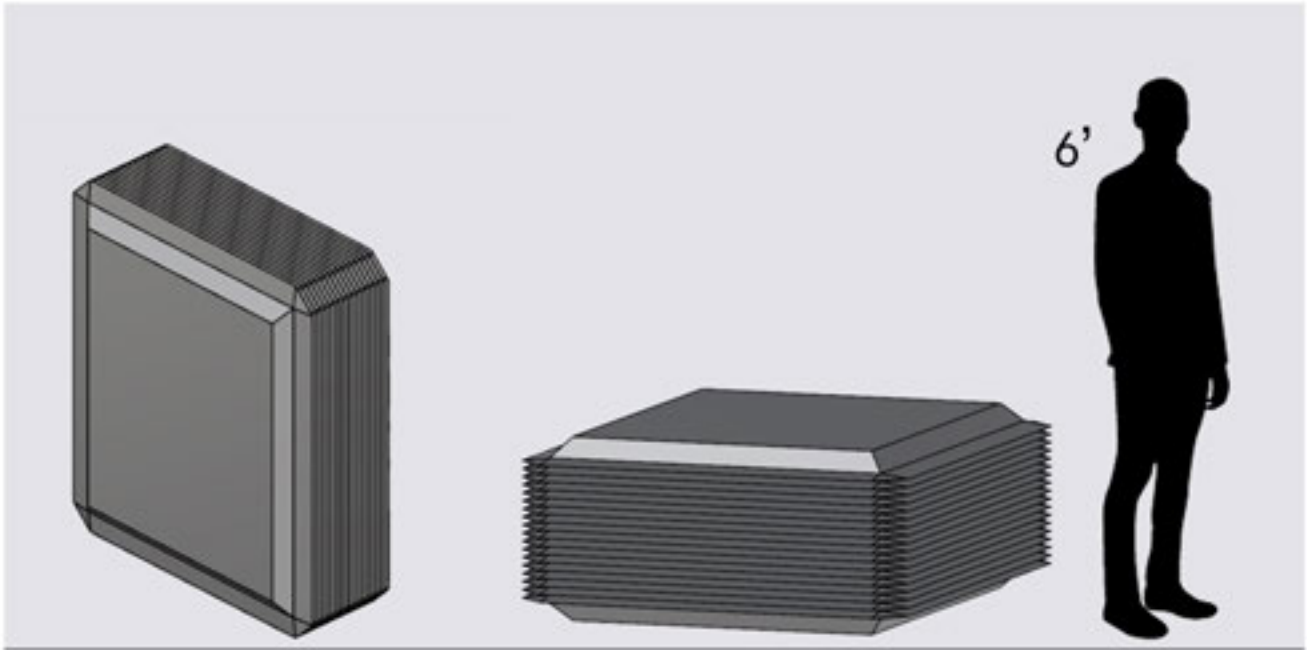



# LET GO/ Furniture

---

**Siqi Lyu**



Sally Lyu is an international junior student, she major in interior design in California College of the Art. She was born in Xiamen, south of China, and she went Carrollton Christian Academy in Texas for high school. She really interesting in Japanese architectural and furniture because of the flexibility and possibility of them. She enjoys to create more possibilities inside of a limit space.

My concept about the furniture is that I want to use lego as a reference to create a flexible furniture for my organization. My organization named "East Bay" which is focusing on help refugees in San Francisco. Recently, the organization want to redecorate their office, but they do not have much money for this program. They want a better working environment and need more space for activities such as private space for talking to people, a large open space for a meeting, a kitchen area, a dining area, etc. So I try to create a furniture which can help them achieve this goal easily.

So, lego is a great form to achieve this goal because I want to redesign the lego, and let each piece can have more possibilities. Consider of the scale of each piece, and the form of it such as a lego with a drawer, a lego with a small shelf, etc. I also want to consider the material, some of them I want to use wood, and others can be plastic. This furniture also design for kids, because they can move each piece around, and create anything they want: a small room or a small bed.



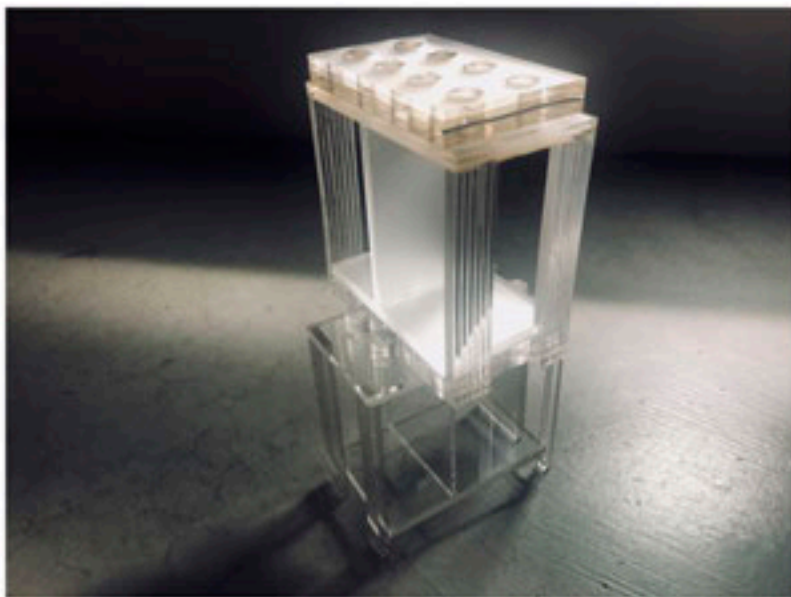
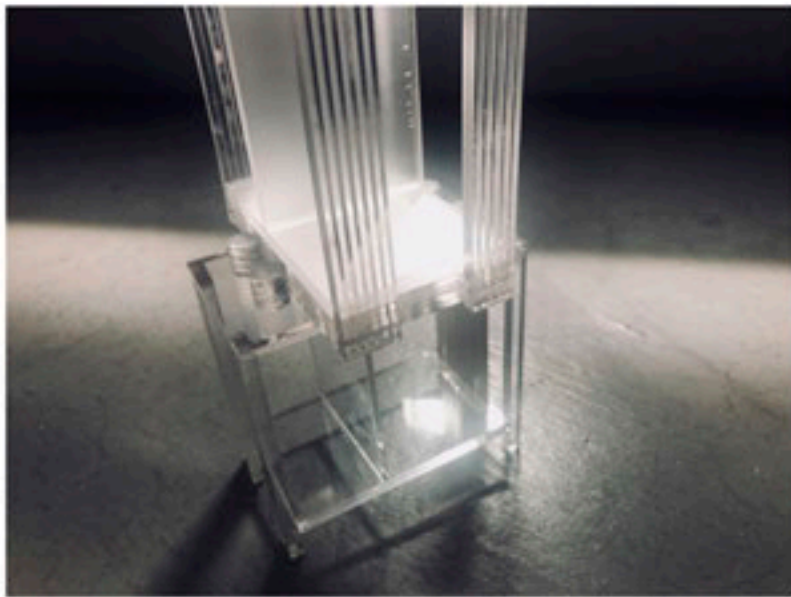

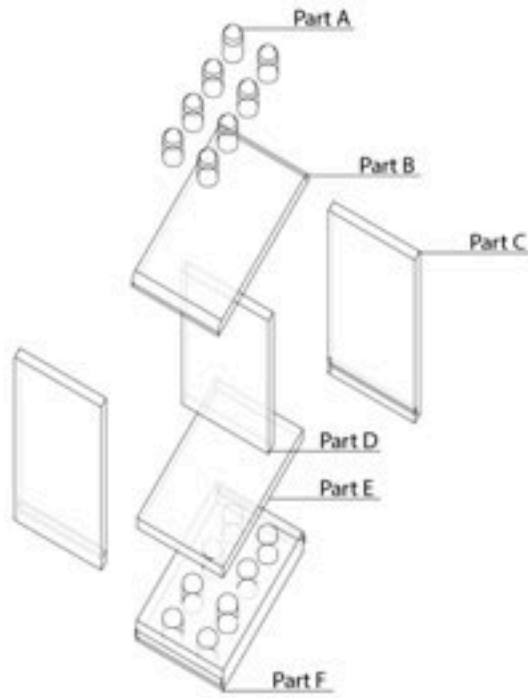
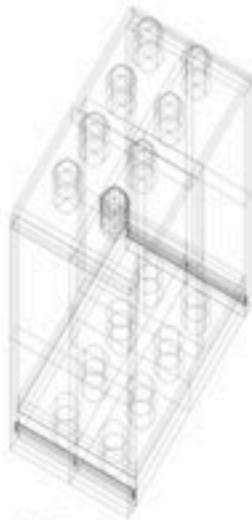
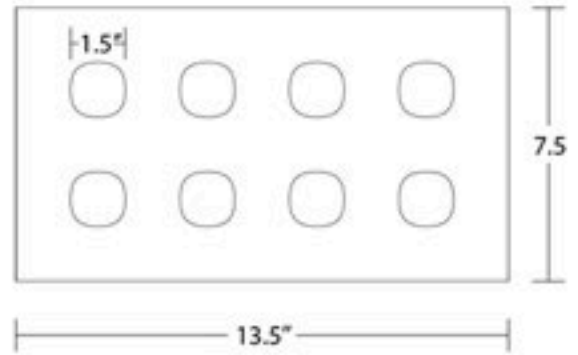
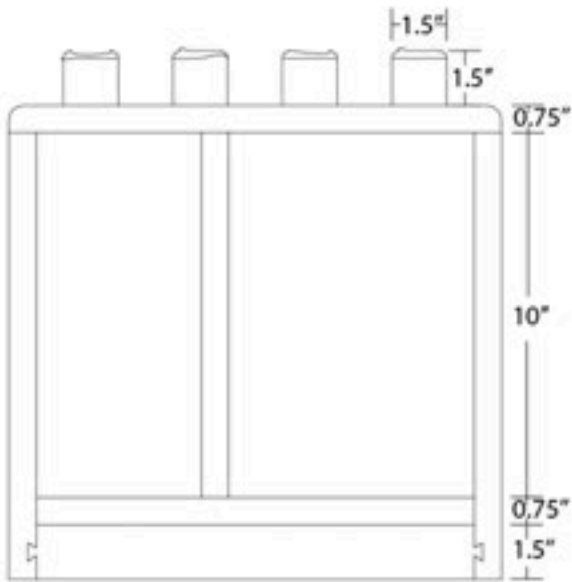

CALL OUT



Part B & Part E



Part C

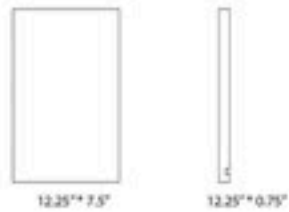

Part D



Part F





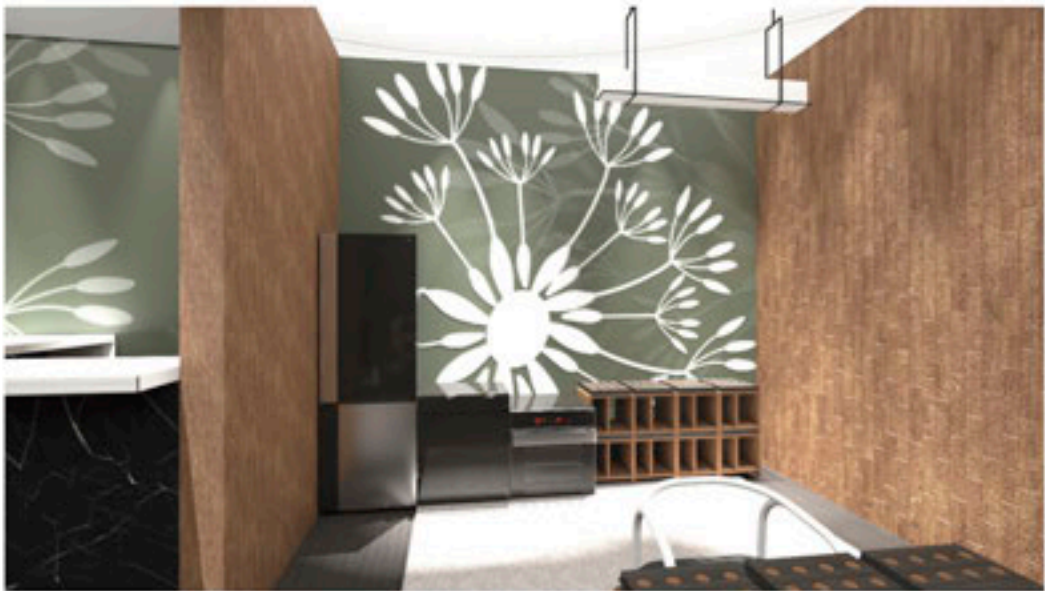

# MYWORKSPACE I

## Art as therapy

---

### Zixuan Yang



Zita is a senior in interior design major at California College of the Arts. With a background in fifteen-year-experience of fine art and painting, Zita's artworks were exhibited several times throughout her career practice. She was born and raised in Qingdao and then moved to Beijing on her own. After moved to the Bay Area, her interests in design and space brought her from an "artist" to a "designer". Each design process is a unique artistic journey for her and her work primarily focus on imaginary experiences by shaping human perception with space, and solving problems creatively.

---

Due to the Trump administration's "Zero Tolerance" policy, many children are separated from their undocumented parents when crossing the border and most of them still remain in government custody. Children sleep on the floor on green mats with an aluminum-based blanket in an ice-cold, chain-link cage. It brings significant negative impacts to their mental health and it is unfair to treat these young people as criminals. This is such a traumatic violation of their rights. It was such a heartbreaking moment to hear about these facts and I was really angry about what the government has done to these children. As a designer, I feel I must take action to help them get through these distressing days.

I came up with the idea of designing a portable art kit as a donation movement towards sponsoring arts education for refugee communities. Unlike traditional art

kits on the market, MYWORKSPACE is a portable, adjustable maker kit, which can be folded into a small flip top desk. Shaped like a carrying travel case, the kit is made from rotational-moulded polyethylene, and consists of multiple storage spaces for art supplies and utility tools. By forming partnerships with a San Francisco based refugee resource center—ARTogether, the kit is going to serve one of the children's arts and crafts workshop called Journal Making. The design aims to create a space for separated immigrant children to express themselves through making their own artistic journal. The creative process enables the unaccompanied minors to explore their inner self and own uniqueness. My hope is to provide a personal therapy space for the refugee children as a way to escape the conditions they have been forced into.





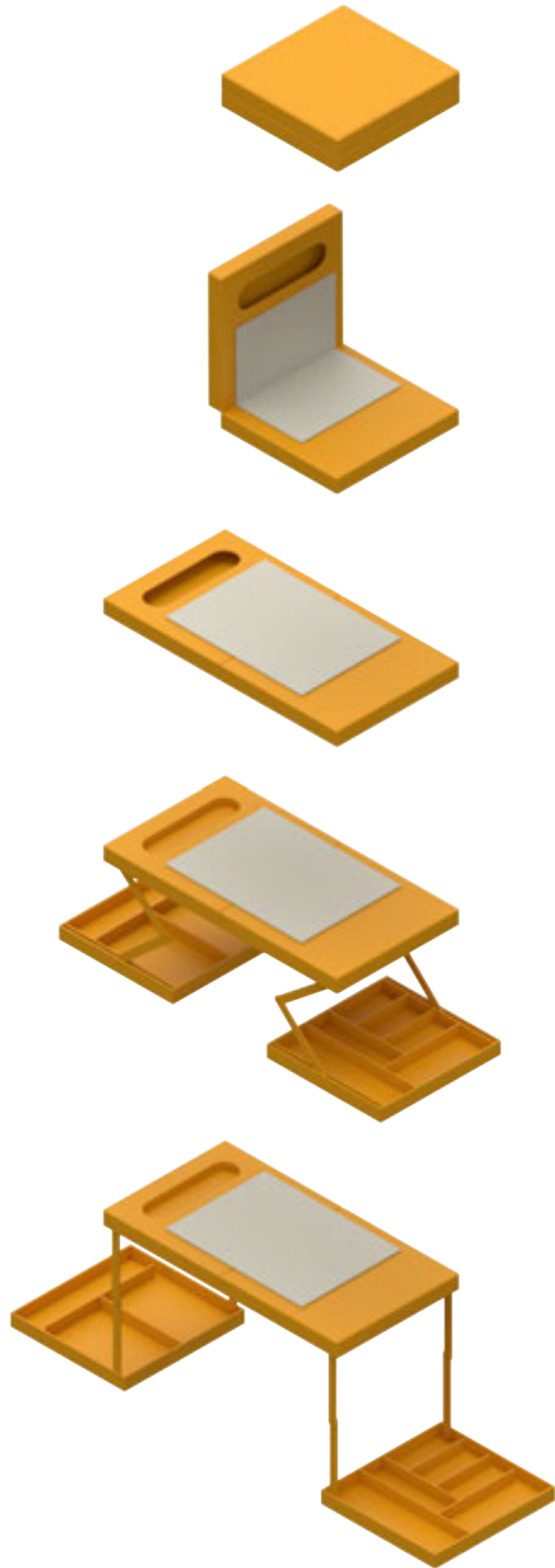



"The parents' presence is also necessary for a person's harmonious growth and development. Premature maturation of stress and threat processing networks in the brains of children separated from parents stunts the child's development and leads to loss of flexibility in responding to danger. The feeling of safety and the associated ability to bond with others, the ability to detect and respond to threat, as well as the ability to regulate one's own emotions and stress are vital," as described in Neuroscience News for June 2.



ARTTogether organizes a variety of children's workshops with multiple organizations, including the International Rescue Committee and the Center for Empowering Refugees and Immigrants. Ranging from picture frame working to tie-dye, our children's workshops encourage youth to express themselves artistically.



# **Accademia Di Belle Arti Palermo**

Student Work



# Hybridsim & Multi-Ethnicity

Ivan Agnello



The phenomenon of migration has today reached epoch proportions: in 2017, the number of people forced in the world to abandon their land for various reasons reached 68.5 million! More than 120,000 migrants have landed on the Italian coast in the last year alone, including 26.5% minors, half of whom are unaccompanied (sources: UNHCR and Save the Children).

The humanistic organizations for the reception of migrants, although present on the Italian territory, appears undersized compared to the vastness of the phenomenon, while the European Community struggles to find a shared political line on mass migration.

Regardless of how we think about the question of the acceptance of peoples and cultures other than our own, temporary or lasting, the phenomenon constitutes an extraordinary opportunity for those working in the project dimension. An opportunity to propose the idea of civil coexistence within an increasingly multi-ethnic and multicultural community.

California and Sicily, Italy were in a Similar situation in having large numbers of immigrants and

refugees approaching the borders in need of asylum, a high percentage of which are unaccompanied minors. Prof. Mariella Poli from California College of the Arts, teaching a course "Hybrid-ism and Multi-Ethnicity with a topic of unaccompanied minors invited us to have an online exchange with our group of students in Design and Methodology at our Accademia di Belle Arti in Palermo. My group of students are designing playful and educational games and/or useful furniture for unaccompanied migrants/refugees between the ages of 0 and 14, temporarily housed in reception centers in Italy.

The intention of these projects is to help with the difficulties of cultural assimilation and diminish the suffering caused the dramatic experiences these children were subjected to during their arduous journey.

This collaborative enterprise will conclude with an Exhibition in Palermo and an online catalog divided in two phases, the first dedicated to project ideas, the second to prototypes.

# Puchi

---

## Chiara Cumignano



Chiara Cumignano was born in Palermo in 1996. Chiara, since childhood has been interested in drawing and art in all its aspects. She studied in a High School specializing in Art and in her third year chose “Set Design” as a field of study. After graduation she joined the Academy of Fine Arts in Palermo with the major of Set Design. Since High School she’s worked in various art/design related jobs such as the Art Museum Exhibition, Theatrical and Cinematographic Work.

Puchi is a blanket that is freely inspired by the shape and the peculiarities of the Sugar Petauro, called improperly flying squirrel; nocturnal animal par excellence, loves company, grows quickly and, due to its small size, appears tender and delicate.

For this anti-panic gadget, intended for the first aid of small migrants, they wanted to combine the typical characteristics of the animal with those of the simplest, most consoling and reassuring object in the world, both for adults and for children: a blanket.

*hi! I'm puchi and I'll keep  
you warm when you need it!*



# PUCHI da "ANIMAL FRIENDS"

*la coperta morbida anti-panico*

# PUCHI da "ANIMAL FRIENDS"

– l'idea di progetto



Un altro tratto che accomuna questi 3 gadget della collezione, è l'uso della *Sahara Geranium*, una particolare trama usata soprattutto nei paesi dell'Africa. La scelta di questi materiali è data dall'idea di far venire a contatto i bambini con fibre, tessuti, e materiali non del tutto estranei alle loro esperienze di vita quotidiana.



*prima immagine in alto: foto dimostrativa della fantasia usata per PUCHI*  
*immagini in basso: foto dimostrative delle fantasie usate per MUKI e HOYO*

# PUCHI da "ANIMAL FRIENDS"

– schizzi digitali (prova colore) / 10.11.2018



*prima immagine in alto: visione frontale.  
seconda immagine: visione posteriore.*

Chiara M. Cumignano

# PUCHI da "ANIMAL FRIENDS"

– modello 3d / 11.11.2018

*visione di tre quarti*



*visione aerea*



Chiara M. Cumignano

# PUCHI da "ANIMAL FRIENDS"

– modello 3d / 11.11.2018

*visione laterale*



*Chiara M. Cumignano*

# Hoyo

---

## Giulia Pagano



Hi, I am Giulia Pagano, I am 22 years old, I am studying Set Design (scenography) at the Academy of Fine Arts in Palermo, through which I have experienced many project such as collaborating with Teatro Massimo for the opera La Traviata. Right now, as well as cultivating my hobbies (planning, sewing and drawing..) I'm also working on a movie with some of my fellow colleagues.

---

This plush is inspired by the Caretta Caretta sea turtles, a very common species in the Mediterranean Sea. They make long migrations (5,000 km) to escape the cold waters. They are among the largest turtles on Earth.

The name Hoyo derives from Japanese and means “to embrace”. Hoyo is a cushion-plush, designed with the longest front legs to allow a tender hug with the child ...

The carapace is padded in such a way as to become a soft pillow and thus favor the sleep of the child.

# HOYO

(da "ANIMAL FRIEND")

Una collezione dedicata alle necessità dei **bambini immigrati**, composta da tre giocattoli **multi-uso portatili, anti-panico** e progettati per fornire il massimo del comfort grazie alla scelta dei materiali e del design semplice ma accattivante. Le **forme zoomorfe** sono ispirate a tre animali da tre habitat differenti: **coniglio, scoiattolo volante e tartaruga marina**, rispettivamente per **terra, aria e acqua**. L'utilizzo è consigliato dai **tre ai dodici anni**, senza distinzione di sesso.

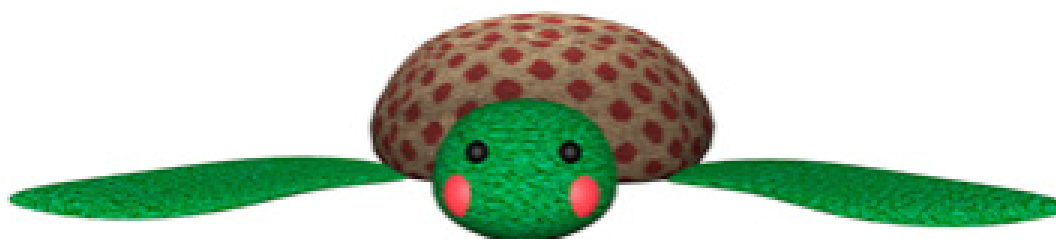

Questo peluche si ispira alle tartarughe marine **caretta caretta**, una specie molto comune che possiamo trovare nelle **acque tropicali e nel Mar Mediterraneo**. Compiono migrazioni lunghissime (5000 km) per sfuggire alle acque fredde. Le tartarughe caretta caretta sono le **più grandi** sul nostro pianeta. Il nome **HOYO (抱擁)** deriva dal giapponese e significa **abbracciare**. Hoyo è un **cuscino peluche**, è progettato con le zampe anteriori più lunghe per consentire al bambino di abbracciarla. Il **carapace** è imbottito in modo tale da renderlo anche un morbido **cuscino** e favorire il sonno.

## TEXTURE

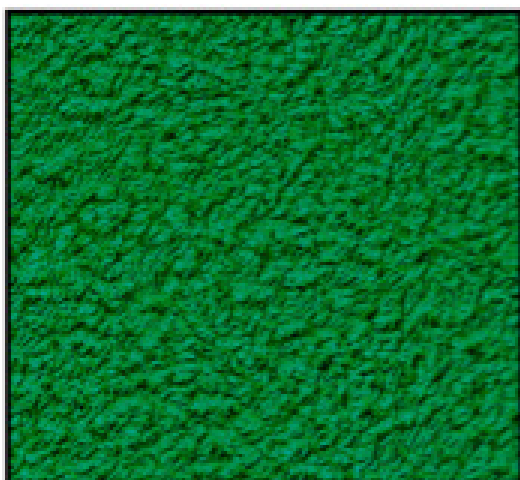

COTONE MORBIDO DI COLORE VERDE, UTILIZZATO PER LE ZAMPE ANTERIORI, POSTERIORI E PER LA TESTA. AL TATTO RENDE IL PELUCHE MOLTO MORBIDO E CONFORTEVOLE.

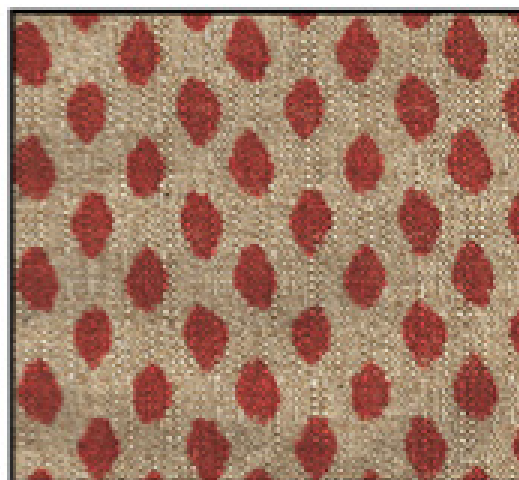

FANTASIA SAHARA GERANIUM IN COTONE CREZZO. UTILIZZATO PER IL CARAPACE. LA BASE E' DI UN COLORE SIMILE ALLA SABBIA MENTRE I ROMBI INTERNI SONO ROSSO SCURO

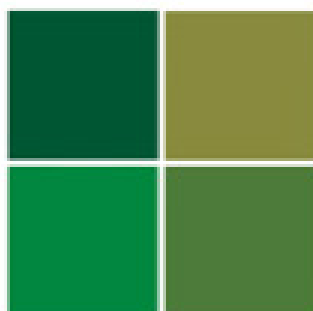

PALETTE COLORI

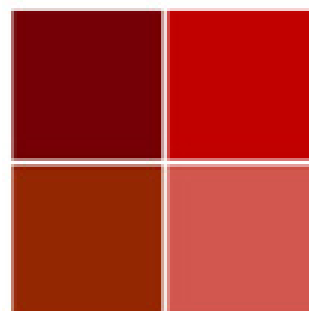

PALETTE COLORI

## MISURE

(3ANNI: 94cm - 12ANNI: 1,47 cm)

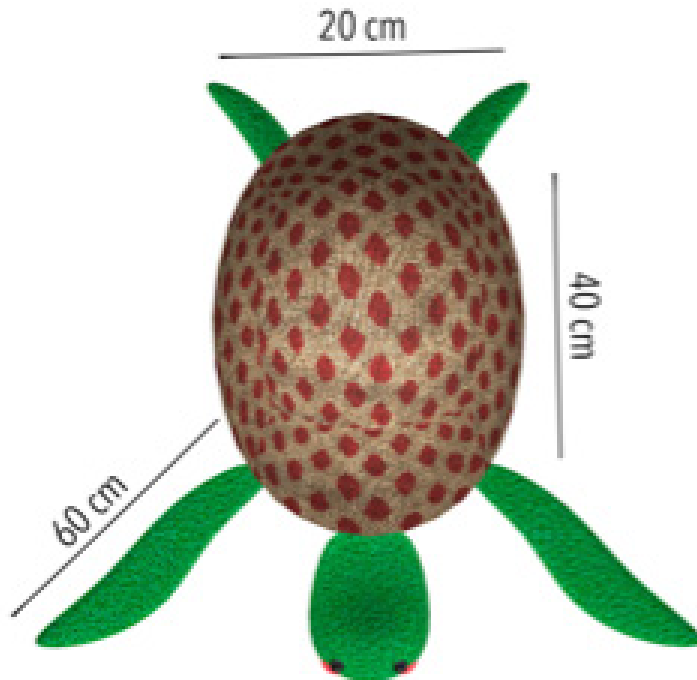

Dopo essermi documentata sull'**altezza media** dei bambini nella fascia d'età dai **3 ai 12 anni**, ho realizzato il giocattolo della dimensione secondo me ideale e che si adatta meglio alla **struttura del bambino**.

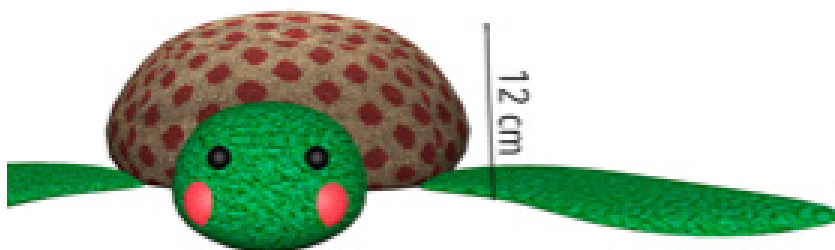
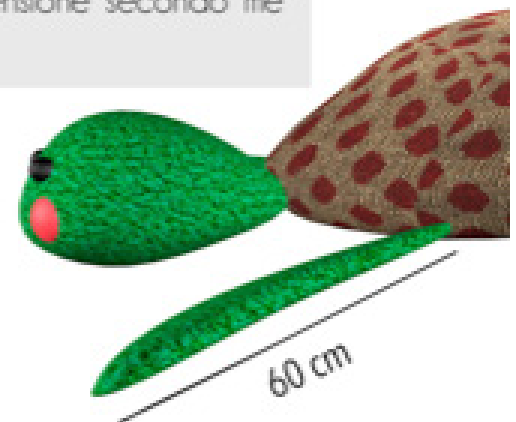

# Muki

---

## Giulia Fulvio

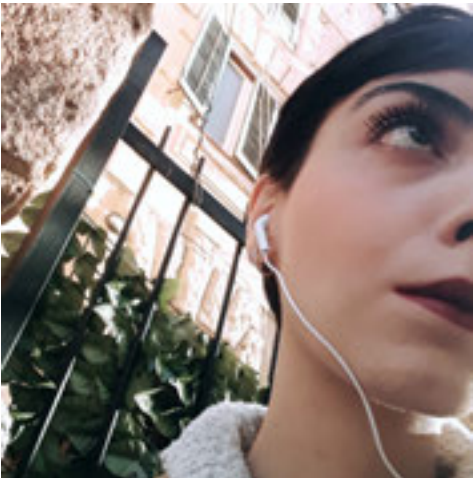

My name is Giulia Fulvio and I am 21 years old. I am currently studying Scenography at the Academy of Fine Arts in Palermo (where I was born) and in these years of learning I have worked for various departments of the Theater and Cinema world, from the design and realization of scenographies to the costume design and make-up part. Later I developed a passion for illustration and I have studied in parallel both things, trying to make a profession of my eternal love for drawing.

Muki is inspired by a basic technique to combat panic attacks: if you are in hyperventilation, you can help to resume the regular rhythm of breathing by drawing with your fingers a square in contact with the skin, counting the segments that make up, as many times as necessary to calm down.

Muki inspires a sense of well-being, thanks to the subtle color and soothing tones and the simple design, reminiscent of a childhood toy, makes it friendly, as a small reference point everywhere, at all times, without being afraid of having to attract attention on yourself.



## MUKI ( da " ANIMAL FRIENDS " )

Una collezione dedicata alle necessità dei bimbi immigrati, composta da tre giocattoli multi-uso portatili, anti-panico e progettati per fornire il massimo del comfort grazie ai materiali e al design. Le forme sono ispirate a tre animali da tre habitat differenti: coniglio, scoiattolo volante e tartaruga, rispettivamente per terra, aria ed acqua. L'utilizzo è consigliato dai tre ai dodici anni di età, senza distinzione di sesso.



## dettagli

---



tasca  
frontale

gancio  
e cerniera



\* gadget, pupazzo,  
borsa a tracolla,  
zaino



palette

m i s u r e

---

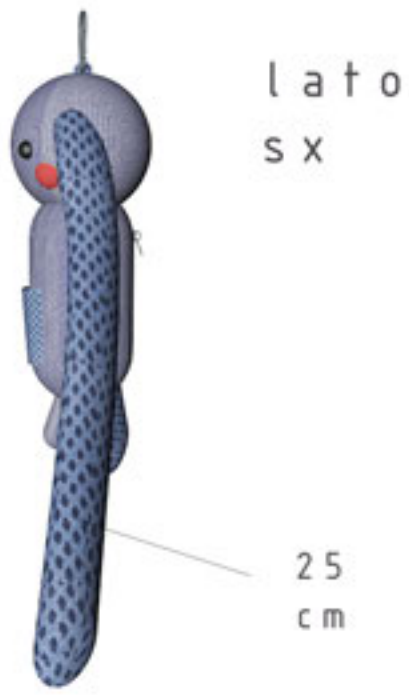
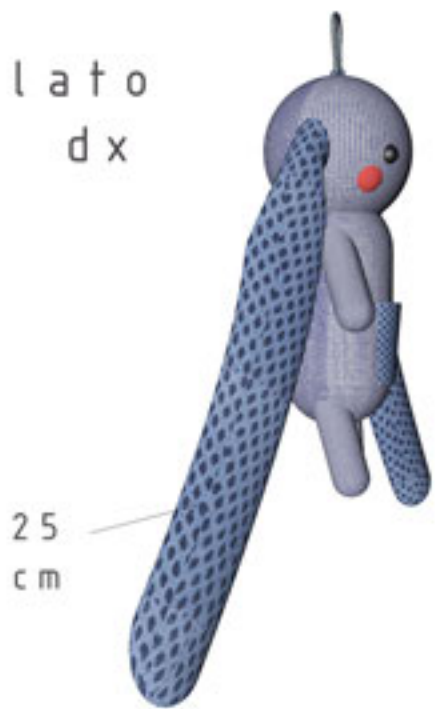
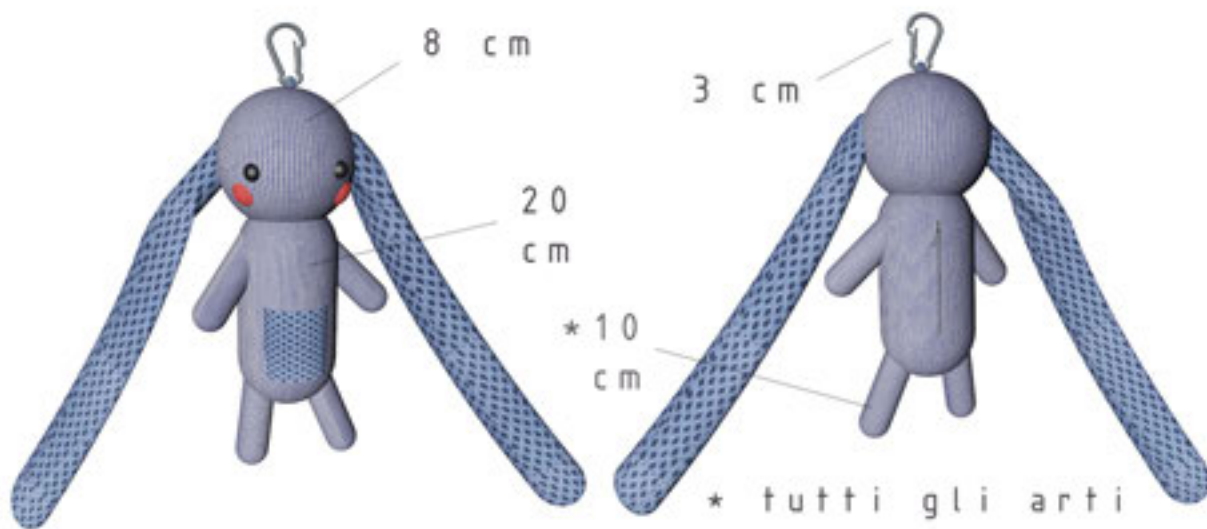

# Cuccioland

---

## Chiara Sempreviva



Chiara Sempreviva was born in Palermo 1992. Graduated in the 2015/2016 academic year in Decoration at the Academy of Fine Arts in Palermo, she is currently in the second year of the two-year sculpture course.

“Cuccioland” is a comfortable and soft backpack of stuffed animals that turns into a small play tent. An intimate place to recreate your nest, a place of fun and rest. The awning is self-assembling and incorporated into the backpack and does not require stakes, it is easy to assemble and disassemble. The backpack has a circular shape with its diameter measuring 37 cm; the circle is the geometric shape most appreciated by children and is associated with the mother figure.

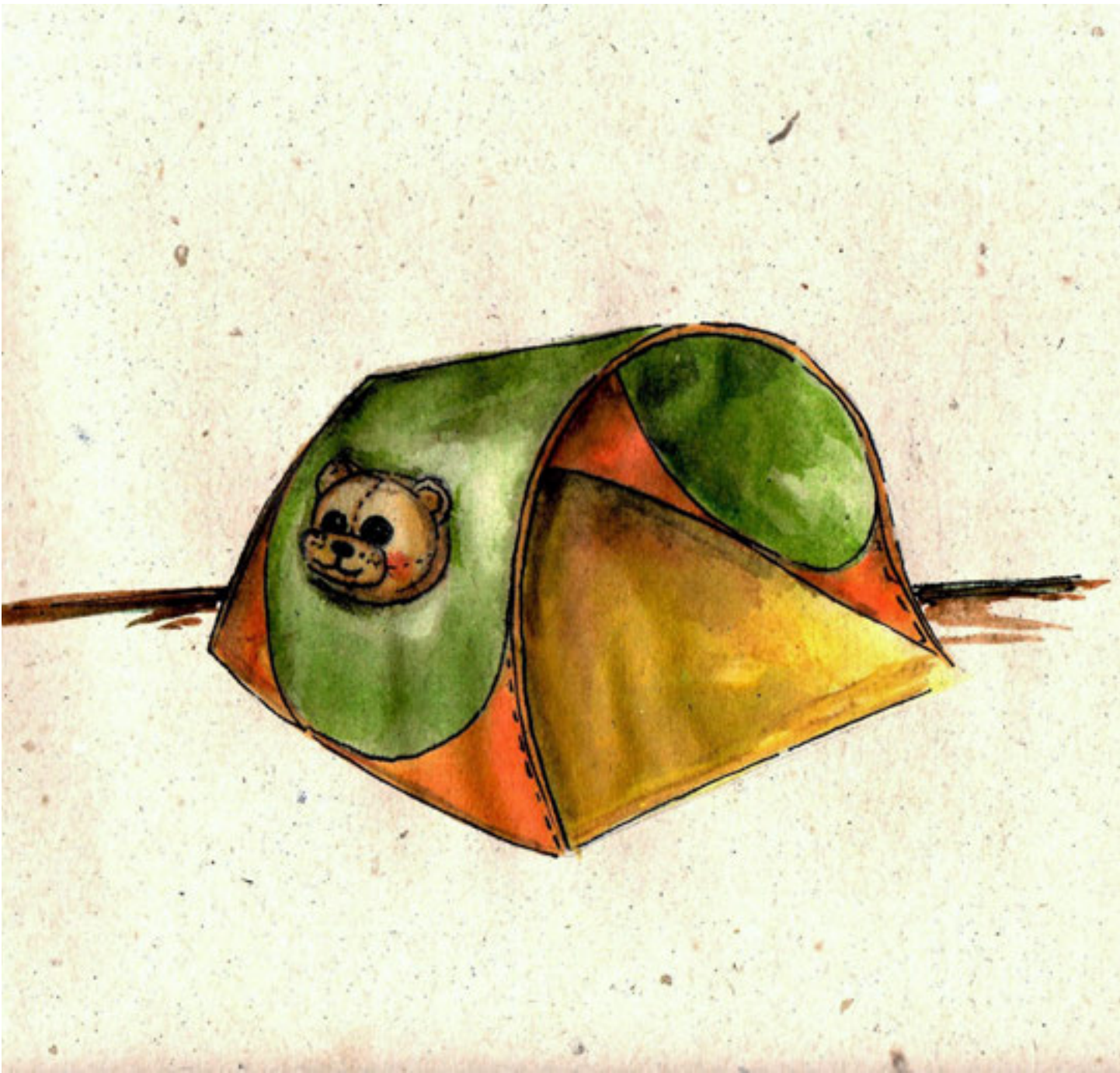



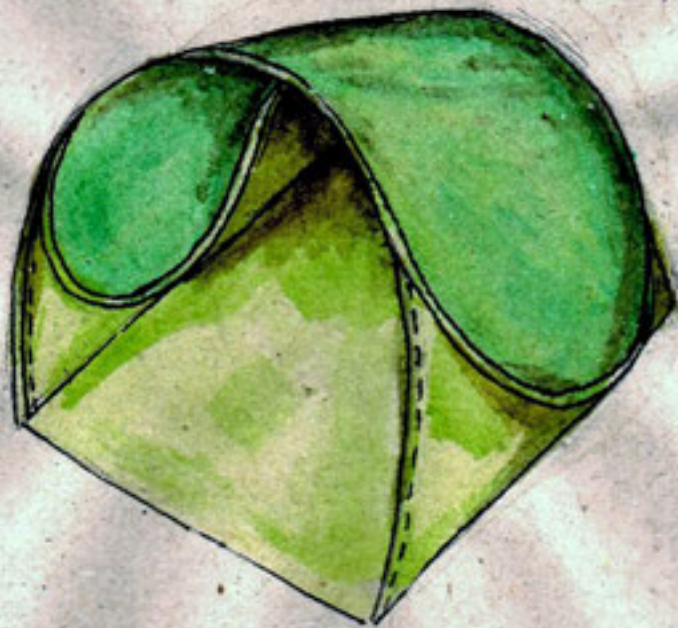

# HUGO

---

## Giulia Terzo



Giulia Terzo, was born in Palermo (Sicily) in 1998. She graduated from a linguistics high school and currently is in her third year of exhibition design at the Academy of Fine Arts of Palermo. She is interested in design and fascinated by the study of materials, light and the relationship between the two.

A hug means “You’re not a threat, I’m not afraid to stay close to you, I can relax, feel at home, I’m protected, and someone understands me”.

Paulo Coelho

Starting from the classic shape of a life jacket, my project aims to modify some aspects of it in order to facilitate the child’s approach to first aid. The arms of the character on the front of the jacket replace the classic belt simulating a hug. Furthermore, the new proposal fulfills two different functions: subsistence (figure 1) and a sitting / mattress (figs 2 and 3) to allow the child to rest comfortably during the journey and to have an object of his own property with which to share adventures and gain security and awareness of the new space in which he is in. The proposal will remain in compliance with the regulations of a lifejacket, respecting it in its forms, materials and colors. The different colors will be combined with different characters whose definition is still undetermined.

## HUGO The life jacket

*A hug means "You're not a threat, I'm not afraid to stay close to you, I can relax, feel at home, I'm protected, and someone understands me".*

Paulo Coelho



### CONCEPT

Starting from the classic shape of the life jacket, the project aims to modify some aspects in order to facilitate the child's approach with the first aid. The arms of the character on the front of the jacket replace the classic belt simulating a hug. Furthermore, the new proposal fulfills two different functions: the subsistence one (figure 1) and the one of sitting / mattress (figs 2 and 3) to allow the child to rest comfortably during the journey and to have an object of his own property with which to share adventures and gain security and awareness of the new space in which he is. The proposal intends to remain in compliance with the regulations on lifejackets, respecting it in its forms, materials and colors. The different colors will be combined with different characters whose definition is in progress.

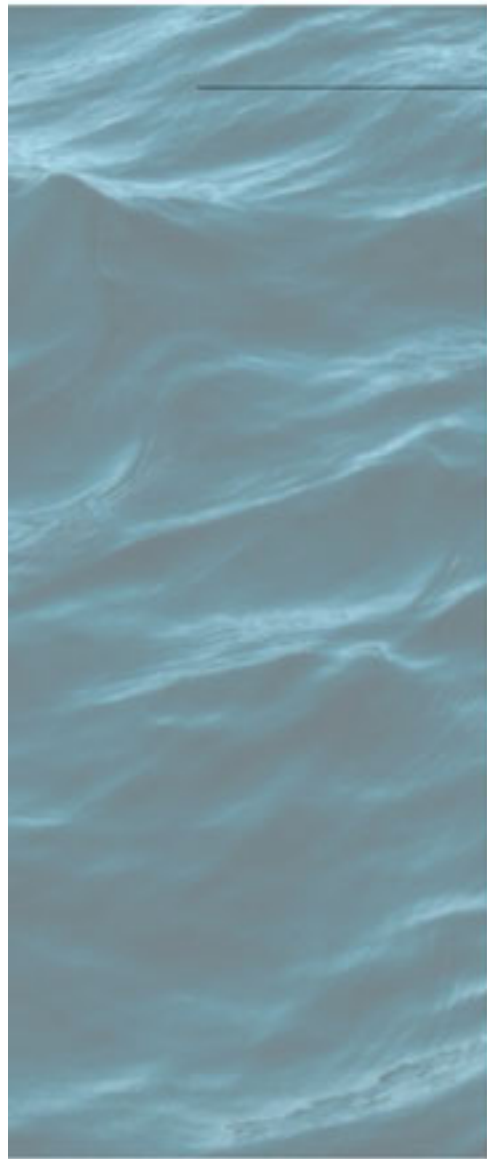

**HUGO**  
The life jacket

Kid size (10-20 kilos)

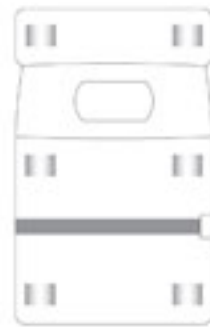
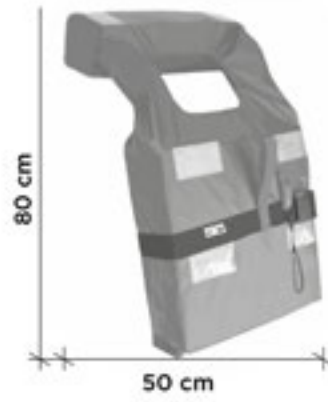

**MATERIALS**

Polyester



Reflective bands



**COLORS**





# BADRU

---

## Giuliana Barbano



Giuliana Barbano was born in 1992 in Catania. She attended Enna's Liceo Linguistico and in 2012 she enrolled in the Faculty of Architecture who abandoned to enroll at the Academy of Fine Arts in Catania from 2014 to 2018, because she believes that this could give her greater freedom of artistic experimentation.

During his academic career she participates in several collective exhibitions such as: Art Factory in 2015 at Le Ciminiere di Catania, Artist Book in 2017 at the Emilio Greco Museum in Catania, Dodecaedro in 2017 at the Studio 71 Art Gallery in Palermo.

In 2017 she also exhibited at the Biennial of the artist's book at Castel dell'Ovo in Naples and in 2018 she had the opportunity to exhibit alongside several artists at Palazzo S. Elia in Palermo at the exhibition entitled Artist's Scriptures, organized as a collateral event in Manifesta.

---

*badru* è un progetto che nasce dalla riflessione sul viaggio dei bambini.

Ognuno di noi da bambino ha affrontato un viaggio e sicuramente la luna è stata sempre un punto di riferimento, qualcosa che ci *insegue* e che ci dà conforto con la sua *luce*.

Ogni bambino che è in noi ha avuto paura del buio almeno una volta.

Dalla nostra parte del mondo tutti i bambini hanno una luce che li *consola*, spesso però, dall'altra parte del mondo, questa luce non esiste... questo progetto vuole essere quindi un oggetto di *affezione* che richiama alla mente di questi bambini qualcosa che è stato forse per loro un punto di riferimento in *mare*, la *notte*, dove spesso nascono.

Lo porti con te come uno *zaino*, lo apri ed è fatto per dare sostegno e calore; una *luna* come *cuscino* ed un *cielo* come *coperta*.

*badru* is a project that comes from reflection on children's travel.

Each of us as a child has faced a journey and surely the moon has always been a point of reference, something that follows us and that gives us comfort with its light.

Every child in us has been afraid of the dark at least once.

From our part of the world all the children have a light that consoles them, often however, on the other side of the world, this light does not exist ... this project therefore wants to be an object of affection that reminds the mind of these children something that it was perhaps for them a reference point at sea, at night, where they are often born.

Take it with you like a *backpack*, open it and it's done to give support and warmth; a *moon* like a *pillow* and a *sky* like a *blanket*.

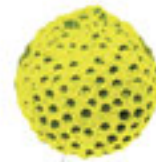

*badru*

"nato durante la luna piena"

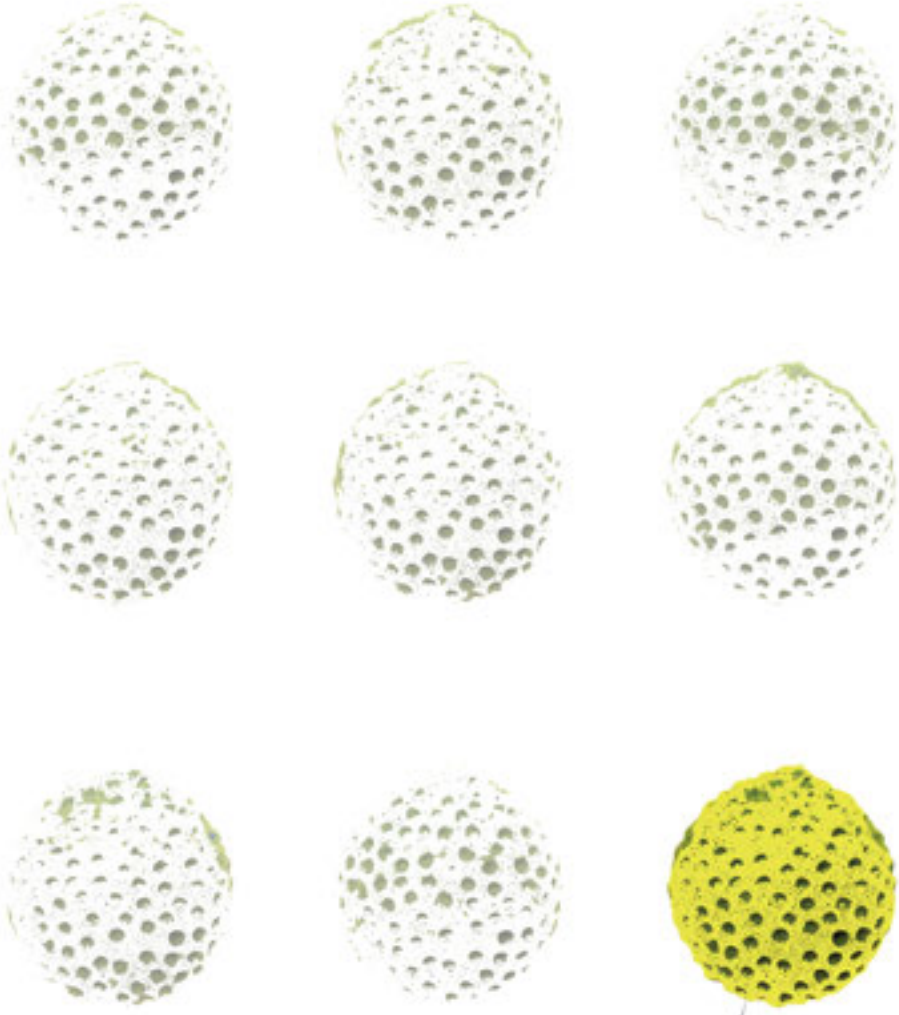

*badru*

*"nato durante la luna piena"*



Unico punto nel cielo di notte

La luna al guinzaglio

Con te la luna è buona,  
mia savia bambina:  
se cammini, cammina  
e se ti fermi tu  
si ferma anche la luna  
ubbidiente lassù.

È un piccolo cane bianco  
che tu tieni al guinzaglio,  
è un docile palloncino  
che tieni per il filo  
andando a dormire lo leghi al cuscino,  
la luna tutta notte  
sta appesa sul tuo lenzino.

da I LIBRI DELLA ANTROPIA di Gianni Rodari - disegni di Bruno Munari

tambidi



il viaggio



la luna



L'immaginazione



La panna



dove siamo?

quando arriviamo?

siamo arrivati?



La luna di Kiev

Chissà se la luna  
di Kiev  
è bella  
come la luna di Roma,  
chissà se è la stessa  
o soltanto sua sorella...  
- Ma son sempre quella -  
la luna promessa  
- non sono mica  
un beneio da notte  
sulla tua testa!  
Viaggiando quasi  
faccio luce a tanti quanti,  
dall'India al Perù,  
dal Tevere al Mar Morto,  
e i miei sogni viaggiano  
senza passaporto.

da I LIBRI DELLA ANTROPIA di Gianni Rodari - disegni di Bruno Munari



da qui



- \* i bambini e la paura del buio
- \* la luce ai ogni cosa e da dove?
- \* protezione e sicurezza
- \* la luce per le strade



per dare una parte

Pensieri  
...dal satellite



LA NOTTE



immagini notturne  
dal satellite



Luna come...

- \* dare conforto
- \* luce come nuova prospettiva
- \* luce come compagna di viaggio
- \* luce come presenza

LA NOTTE

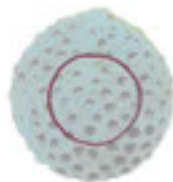
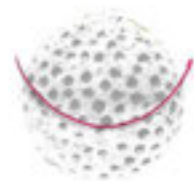
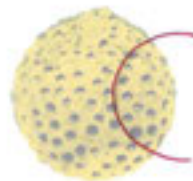
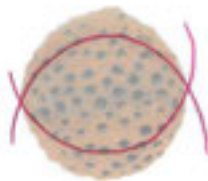

FASI LUNARI

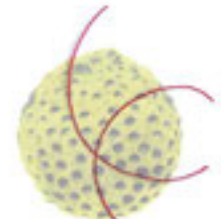
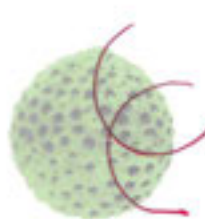
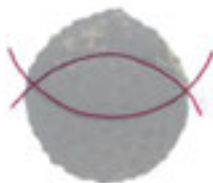

PUNTO DI RIFERIMENTO  
*luna*

FASI  
LUNARI

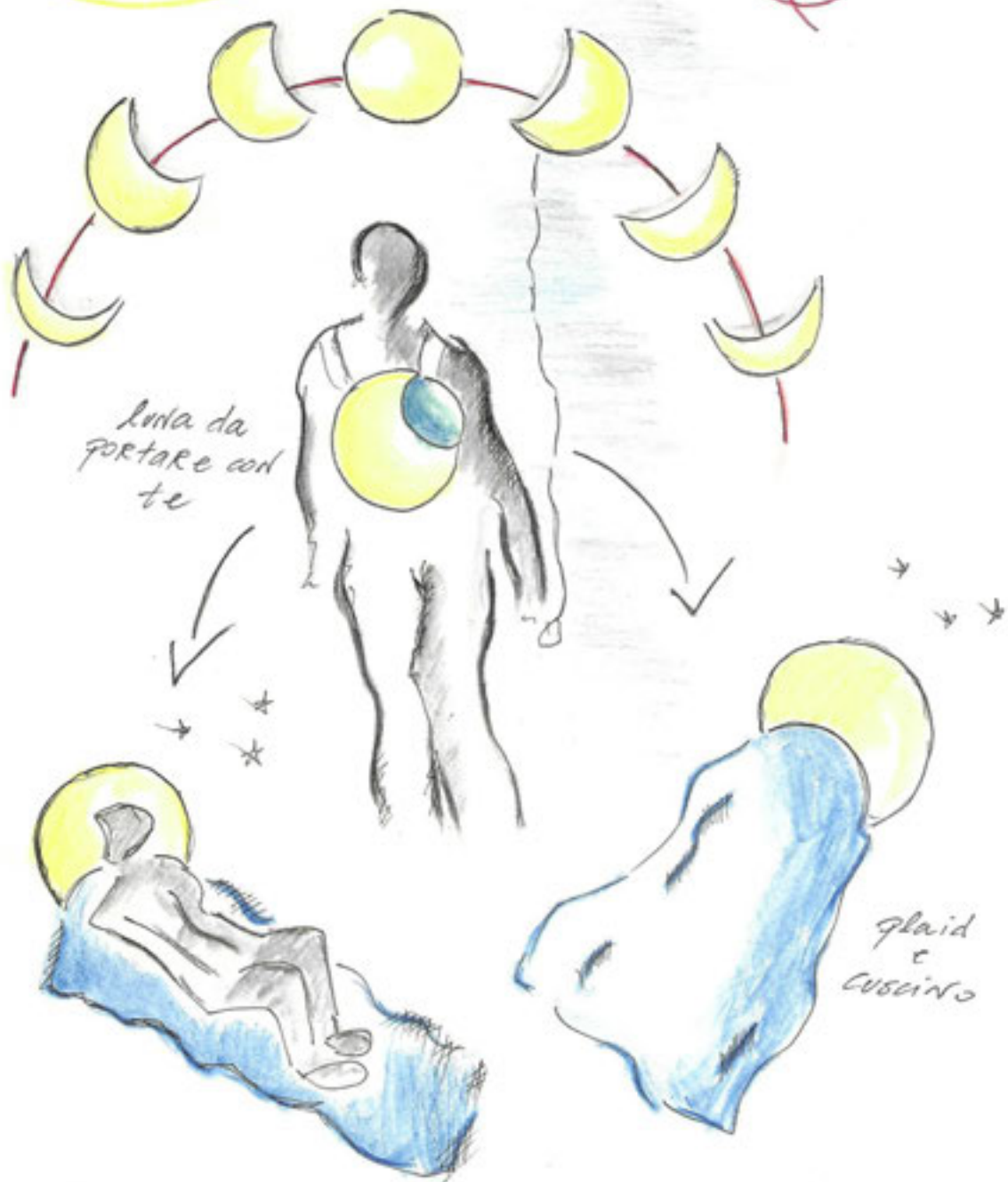

*luna* come punto di riferimento  
come sostegno  
come prospettiva  
come luce nel cielo e nell'anima

landmarkmoon

B



# Butterfly

---

## Marzia Acquaro



Marzia Acquaro is 23 years old and a student of the Academy of Fine Arts in Palermo. I am grateful for the opportunity that was given to me by participating in this project; I am sure that the comparisons between the two groups will lead to cultural and personal understanding.

My project is to make a multipurpose sleeping bag in the shape of a chrysalis. Once opened, the sack will become an interactive carpet in the shape of a butterfly; I have also chosen this figure to give a sense of welcome and fun, thanks mostly to the liveliness of colors.

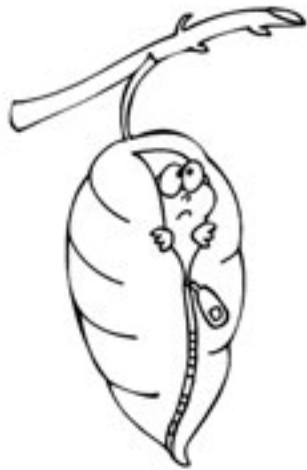

# Waterproof Cape

---

## Sara Carramusa



was born in Palermo, studied at the E. Catalano Art School and attended the Sculpture Department at the Academy of Fine Arts in Palermo. She has also studied Skené, illustration and photography.

My project is to create waterproof capes that could be donated to immigrant children at the time of their reception into Italy. These capes recall the shape, color and details (like the ears, the snout, the tail) of nocturnal animals. A family of raincoats that protect the children who wear them from the elements when it is dark.



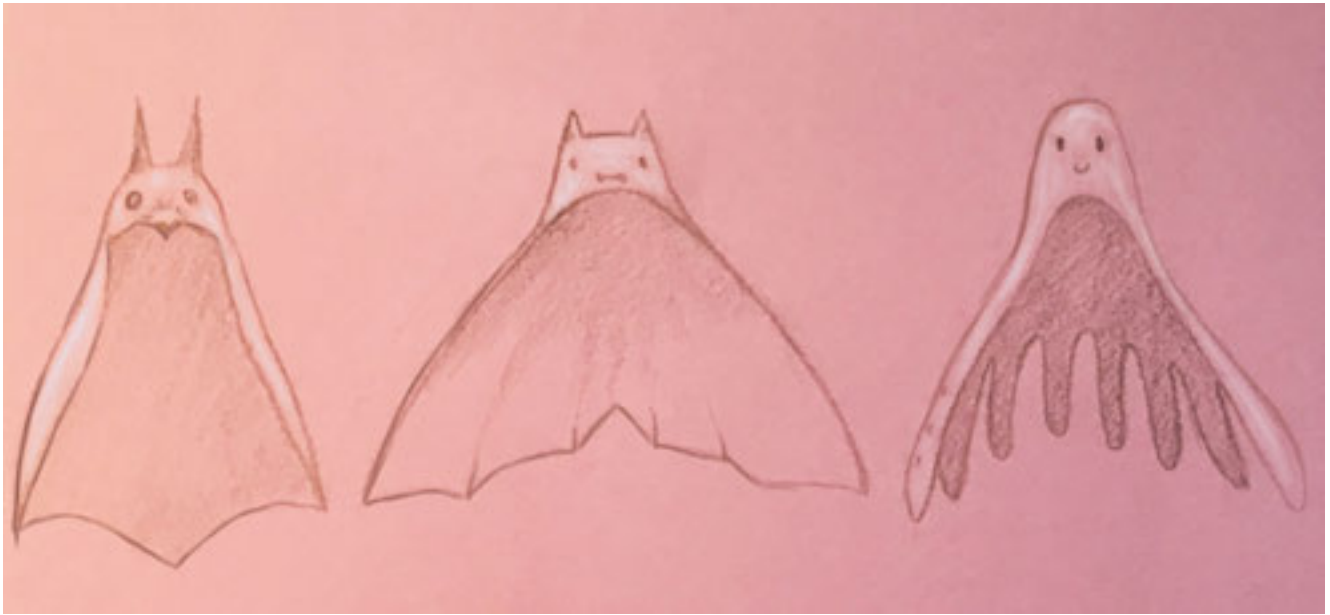



# IL VIAGGIO DEL CARILLON

---

## Serena Plano



Serena Plano is 25 years old. She is a student in the Decoration Program at the Academy of Fine Arts in Palermo. She is passionate about art and happy to attend many different courses at the Academy. Her intent is to receive an advanced degree with the hopes of being able to teach and pass along all that she's learned over the years.

My project is a game designed to give a little 'comfort to children who come from a difficult reality.

My game "IL VIAGGIO DEL CARILLON" is designed to give joy to the child through music, light and colour displaying three silhouettes of cities which represent the place of origin, the city that hosts them and a place of the future.

It is a symbolic journey where the child can identify with and through which they can dream, imagine and hope for something better in the future and is a sensory game able to attract the child's attention and curiosity.

"IL VIAGGIO DEL CARILLON"

PLANO SERENA

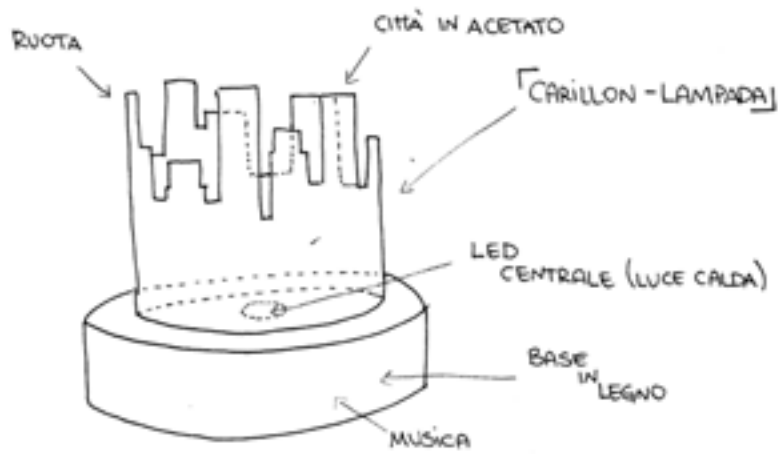

SCENARI

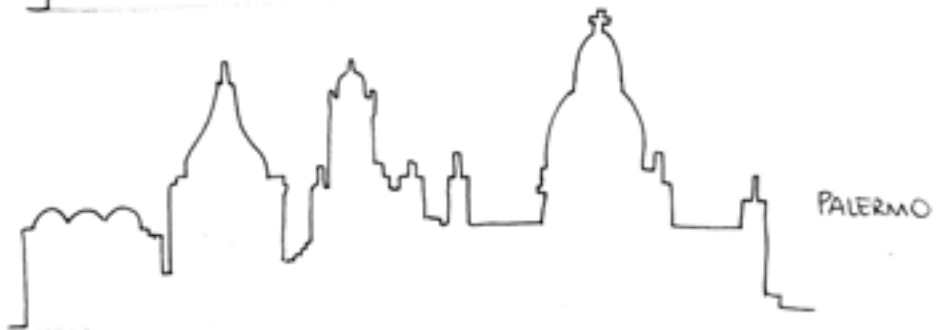

# TORTOISE BACKPACK

---

## Valentina Matranga



Valentina Matranga is 23 years old and is in the second year of the first level Sculpture course at the Academy of Fine Arts in Palermo.

TORTOISE BACKPACK is a backpack that contains a cape that the child can wear that provides shelter and heat at the same time. The backpack is the shape of a turtle's carapace and the coat is designed in such a way as to make the baby wearing it look like a tortoise.

# TURTLE BACKPACK



## Soft Blue

---

### Valeria Gabriel



Valeria Gabriele was born in Rome on 11 November 1990. She moved to Trapani at an early age and has always demonstrated artistic skills, which she did not immediately follow, making a totally different path of higher education.

Fortunately, at the age of 24 she decided to encourage his passions by enrolling at the Kandinsky Academy of Trapani where, last July, she obtained the Degree in Decoration with honors.

She decided to continue his studies, enrolling at the Academy of Fine Arts in Palermo to obtain the specialist in the same field.

It's a soft curtain, made in shades of blue that evoke the dominant colours of the houses and Tunisian majolica.

Here the blue of the fixtures stands out against the blinding white of the walls, creating a very pleasant colour contrast.

"For each child his home" emphasizes how important it is for children to have a family, a place where they can feel safe and safe. Soft Blue wants to be this for them: a place to take refuge and play, where you can invent a thousand stories and always carry with you.



Ad ogni bambino la sua casa





---

## Colophon

This catalog was produced under the guidance and direction of CCA S.A. Professor Mariella Poli, during the Fall 2018 term and in collaboration with Professor Ivan Agnello, Accademia di Belle Arti of Palermo, Italy

Catalog Designed by Justin A. Joseph and Eugina K. Chun

Catalog cover Design by Zita, Zixuan Yang

All typeface is Helvetica.



