



Questions  
of  
identity



# Questions of Identity

Multiculturalism & Identity



# Questions of Identity

Multiculturalism & Identity

California College of the Arts &  
Istanbul Marmara University, Faculty of Fine Arts

2016





# Acknowledgment

---

By Prof. Mariella Poli

I'm very grateful to Prof. Dr. Inci Deniz Ilgin for collaborating on this interdisciplinary Diversity Course exchange between California College of the Arts and Marmara University, Faculty of Fine Arts and sustaining this opportunity for students interested in a fertile international dialog. I would also like to thank all the students from CCA & MUGSF who were willing to work on this project and make an effort to participate in a cross cultural conversation. A special thanks goes to Ashley Adams, for designing our catalog and for customizing and maintaining the class blog.



# Contents

## 10 Introduction

---

Professor Mariella Poli  
Professor Dr. Inci Denzi Ilgin

## 16 Invisible Institution

---

Ashley Adams  
*MFA Design*

## 20 Korean Alphabet

---

Emma Sheochung Cha  
*Painting & Drawing*

## 24 The Many Faces of Bayview

---

Jennifer Gonzalez  
*Architecture*

## 28 Recreate

---

Jasmine Park  
*Illustration*

## 32 Multifunctional Playground for Unaccompanied Children

---

Emma Sheochung Cha  
*Painting & Drawing*

## 36 The Cake

---

Dominique Leal  
*Painting & Drawing*

## 40 Syrian War: The Numb War

---

Edward Lee  
*Illustration*

## 44 Hybridity

---

Morgen Sellier  
*Individualized*

## 48 Ritual Place

---

Artem Struyanskiy  
*Painting & Drawing*

## 52 Gentrification of San Francisco's Mission District

---

Kitty Teng  
*Painting & Drawing*

## 56 Immigrant[e]

---

Joaquin Tobar Martinez  
*Architecture*

## 60 The Garden at The Henry

---

Monica Wongkar  
*Interior Design*

## 64 Mobile Performance Kiosk

---

Willie Jigao Wu  
*Architecture*

## 68 Portable Shuttle Workshop

---

ZiHui Alice Xu  
*Interior Design*

## 72 Public Park & Underground Home

---

Di Yang  
*Interior Design*

## 76 Linguistic Isolation

---

Kaiyian Zhao  
*Industrial Design & Interaction Design*

## 82 Transportation Psychology In The City Life of Istanbul

---

Umut Deniz Aktas  
*Interior Architecture*

## 86 Contrasts of the Silhouette of the People

---

Ogun Canga  
*Interior Design*

## 88 Cultural Metamorphosis

---

Hazma Demir  
*Interior Design*

## 92 How Do You Define Your Identity?

---

Tahsin Emre  
*Interior Design*

## 96 Religious Buildings of Istanbul

---

Bilgehan Ekiz  
*Interior Design*

## 98 Jeans

---

Aykut Gezersu  
*Interior Design*

## 102 Istanbul

---

Busra Onal  
*Interior Design*



# Introduction

Mariella Poli  
San Francisco

---

From a small village built in 1776 called Yerba Buena grew the city of San Francisco with its population from diverse cultures and religious backgrounds; Istanbul with a more ancient history of multi-culture has continued to developed through migration its cultural base. Naturally, in these two cities the question of how cultures integrate and form new identities makes for fertile ground for research and an ideal situation for partnerships in study.

The platform for the artworks on view in this book are a result of a Interdisciplinary Course of Design, Architecture and Art, 'Multiculturalism and Identity' from the Diversity Program, Humanity & Science at the California College of the Arts, San Francisco, in an exchange with Marmara University, Faculty of Fine Arts, Istanbul, Turkey. This book features the artworks from an interdisciplinary and culturally diverse group of artists/designers investigating current and historical perceptions concerning culture and identity in everyday life and their complex relationship to artistic and cultural production. Each body of work represents a unique perception according to each individual's experience, vision and culture identity. Areas and issues under examination include the representation of space both physical and psychological in every conceivable site within our personal and physical boundaries. Memory, race, religion, gender, identity, history are also recurrent concerns that permeate our daily lives and contribute to our understanding of who we are as a culture.

Diversity Studies Studios introduce students to the interrelations between race/ethnicity, art making and design practices. These courses complement the Diversity Studies Seminars with their hands-on approach in which themes of ethnic identity are incorporated into studio and community practices. The individual views in this catalogue are a result of a complete commitment from each participant and their experience, vision, interests and esthetics.

S.A. Prof. Mariella Poli  
Diversity Program, Humanity & Science  
California College of the Arts





# Introduction

Dr. Inci Deniz Ilgin

Istanbul

---

This semester is the eightieth time of our valuable and steadily growing collaboration. In each semester, it has been very inspiring to witness the richness of topics and artistic interpretations that come from multicultural group of students.

Istanbul and San Francisco continue to offer excellent sources with their rich historical heritages that form their current characteristics. Beyond historical richness, today, both cities are constantly receiving large number of immigrants, which adds new layers to their already multicultural quality.

In the past four years over one million people have migrated to Istanbul, bringing its unregistered population to almost 15 million. These immigrants are not only from different parts of Turkey but also from all around the world. As the population of the city grows, the hybridity in social and cultural fabric becomes more obvious.

This semester, Marmara University Faculty of Fine Arts students have focused their attention into topics spanning from tastes of the city to commuters and to international brands and their labor strategies or commonalities and differences to rearranging and shifting urban icons of the cities. They have utilized once again powerful methods to reflect their observations and continued to surprise us. It has been encouraging to witness growing interaction between MUGSF and CCA students, which contributed to the development of the projects.

As before, this has been a great experience for both parts. I would like to extend my sincere gratitude once again to Prof. Mariella Poli for initiating such a fruitful project and making Marmara University, Faculty of Fine Arts and myself a part of it.

Prof. Inci Deniz Ilgin, Ph.D.  
Interior Design Department,  
Marmara University Faculty of Fine Arts





# San Francisco

California College of the Arts

# Invisible Institution

## Ashley Adams

*MFA Design*

Ashley Adams is pursuing her Master of Fine Arts in Design, with a focus on Graphic Design. Her current work focuses on interests of identity and the nuances of an individual. Branding, including visual identities and strategy, is her niche. Ashley is passionate about art and design. When she is not on the computer, she resorts back to her favorite childhood pastime of drawing.

---

To what extent did enslaved Africans perceive their personal histories as a direct continuation of their experiences in the Americas?

The purpose of my diptych is to comment on the lived experiences of slaves and their religious practices. Many other artist like Kara Walker and Hank Willis Thomas have touched on slavery but not specifically on religion. My intention for this piece of work is to provoke thought and will show both slavery as a network and religion in a different perspective.

While many slaves were brutalized to the extent that they died without meaningful forms or social and cultural interaction, many slaves successfully reformulated their sense of identity, and reinterpreted ethnicity under slavery and freedom in the Americas. Religion played a significant role in life of the enslaved Africans. The complexities of African religious history are blurred because of little research on this topic.

The examination of the impact of Christian missions and evangelicalism and the spread of Islam is worth noting. African contribution to the spread of Christianity in the Americas however, is overlooked.

I specifically chose to comment on Christianity and Islamic practices. Slaves who were Christian would hide behind rags or quilts and sing and pray. They would place a bowl of water to capture the echoes, so the sound would not travel. Muslims would wash their feet and faces from a bowl of water and pray many times through out the day. I want to give indexes of these two distinct but similar practices. I want to show there is sameness in differences.





Josiah Wedgwood, "Am I Not a Man and a Brother?" (1787)



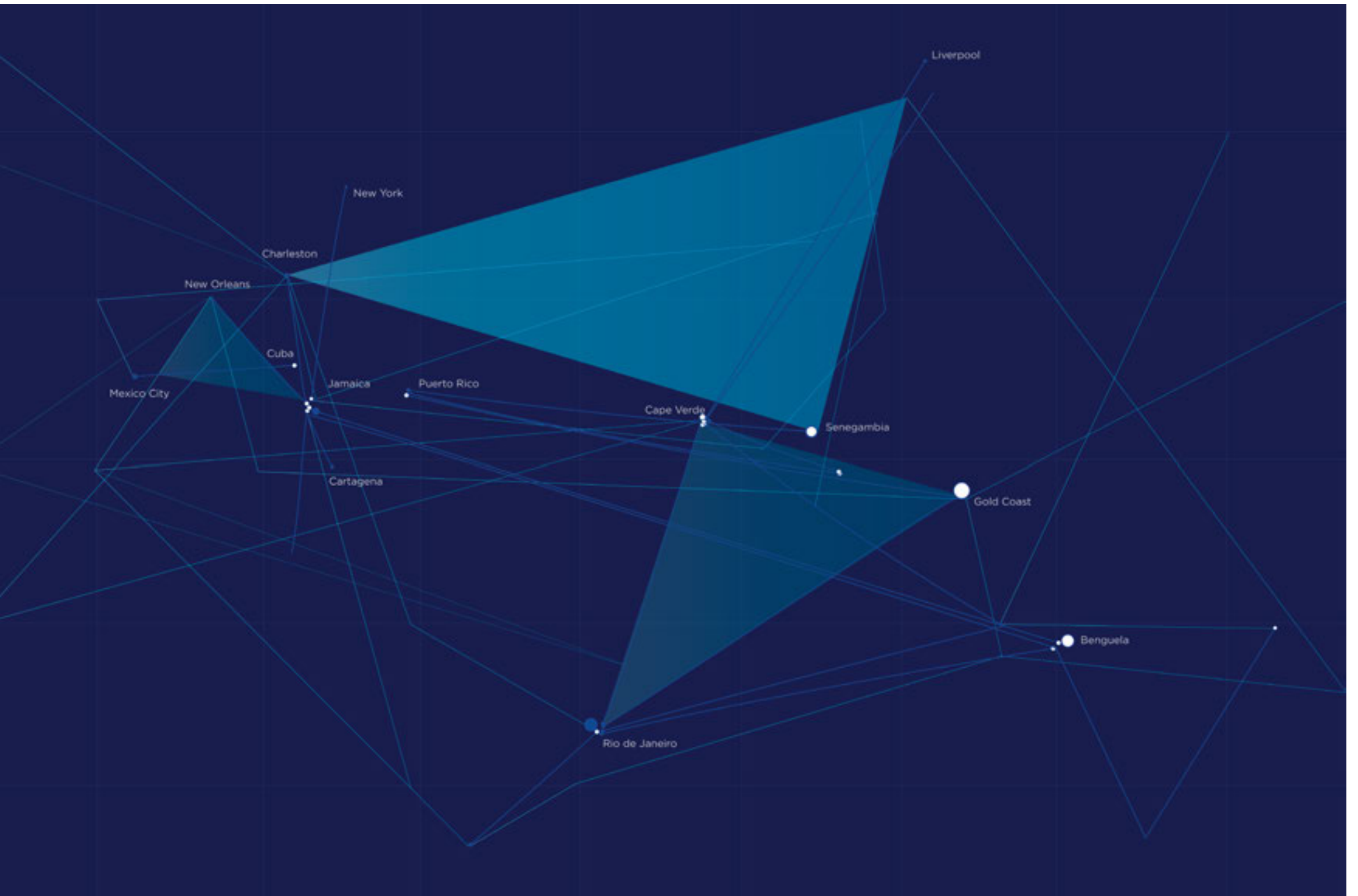



*“Thee we serve, on thee we call for help.”*  
North Carolina, 1831

# Korean Alphabet

## Emma Sheochung Cha

*Painting & Drawing*

Emma is currently a senior Painting & Drawing major at the California College of the Arts. She was born and raised in Seoul, Korea when she was young but she spent her high school life in Middleburg, Virginia. Her two different culture experiences give influence to her artworks. She loves to paint with different mediums such as Oil, Acrylic, Resin, and Textures. Currently she is interested in graphic arts and drawing.

---

My theme is about "Finding myself in the Bay Area". It was difficult to find the exact location of Korea Town; therefore, I contacted one of the largest Korean Churches in San Francisco, "Good Church". I talked with the second generation Korean children from the church, and I realized that their knowledge of the Korean language is very limited because they've been enrolled in American education systems their entire lives, only being required to speak Korean when they are with their families. I realized most Korean American people lose their Korean tongue as they grow up. However, I think it is important to preserve their identity as Korean Americans in a multicultural society. If you lose sight of your ancestral roots, you lose a huge intrinsic shard. We must strive to explore and cherish our heritage, not only to understand previous generations, but to pave ways toward more solid identities for ourselves. The first step would be fluid dialogue, and that is not possible without a reasonable amount of language comprehension. You cannot claim to be multicultural if you only surrender to the common consensus of each country you reside in. You must foster a respect and curiosity for your culture to do so for others.



Throughout our Diversity Studio class, I decided to create a design of the Korean alphabet poster. Rather than doing a painting, I think using my artistic style to create my own Korean alphabet poster can help make learning and memorizing the Korean alphabet easier. The purpose of making a poster is to help teach and promote the Korean language to second generation Korean children. Through good design and intent, I hope they can achieve a steady understanding of the Korean language. I would like to inspire my Korean American peers to further enhance their love and curiosity for the Korean language because there are so many subtle nuances and attitudes tucked away in the Korean language that you cannot express in English. English is practical and universal, but Korean offers a different sense of warmth and beauty.

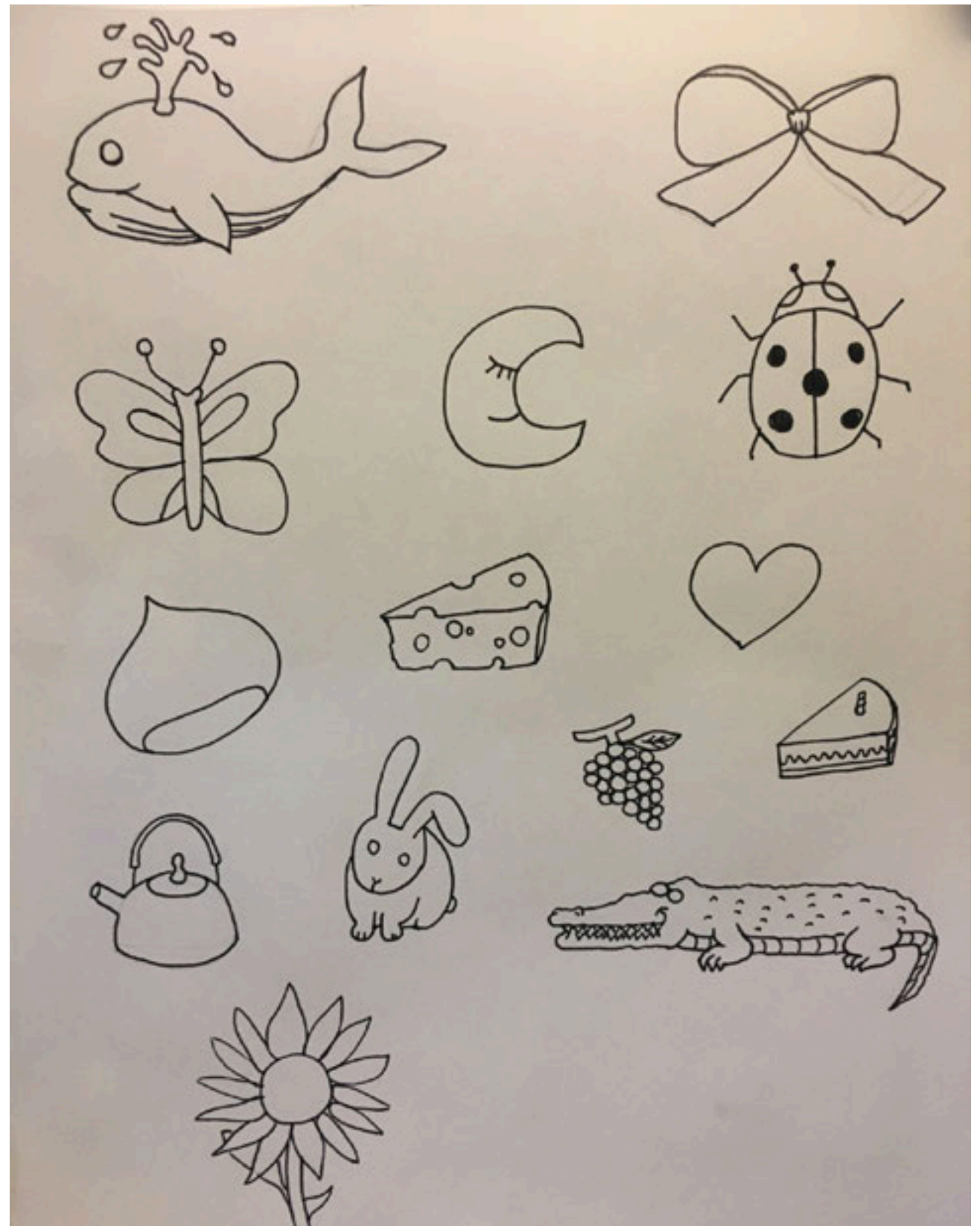



Korean alphabet called : Hangeul 한글  
 combination with consonants and vowels

These are the example of consonants and what it sounds like



ㄱ = k

ㄴ = n

ㄷ = d

ㄹ = r/l\*

ㄴ = m

ㄴ = b

ㄴ = s

ㄴ = j

ㅇ = h

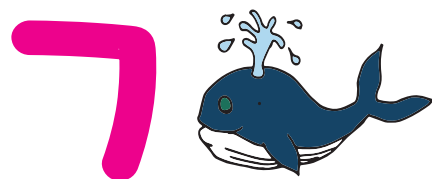

기억 • 고래

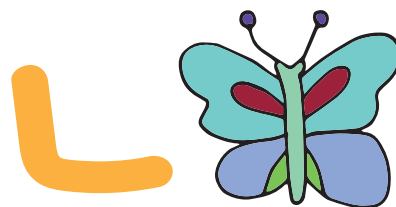

나은 • 나비



달은 • 달걀

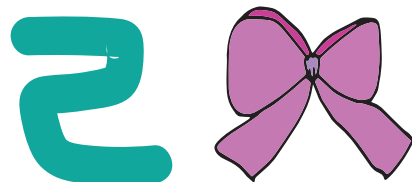

리얼 • 리본

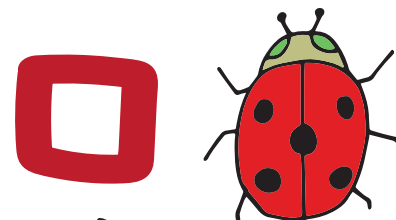

미움 • 무당벌레



비움 • 밤



시웃 • 사랑

Let all your things  
be done in LOVE.

너희 모든 일을 사랑으로 행하라.

corinthians 16:14

고린도전서 16:14



이응 • 악어

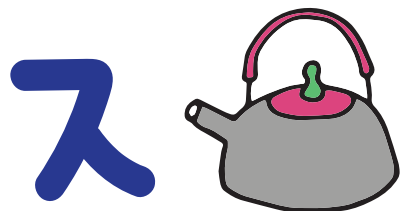

지웃 • 주전자

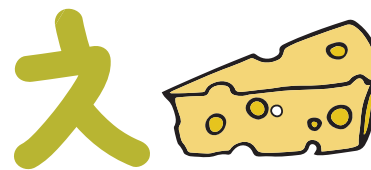

치웃 • 치즈



키웃 • 케이크

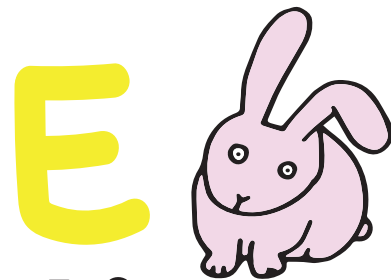

티웃 • 토끼



피웃 • 포도



히웃 • 해바라기

## The Many Faces of Bayview

### Jennifer Gonzalez

*Architecture*

Jenny is a 4th year architecture student at California College of the Arts. Born in Miami, Florida, but raised in the Bay Area she feels a strong connection to Northern California and the community that is here. Miami represents her foundation but living in the Bay Area with all of its opportunities and influences helped her become the woman she knew she was. As a first generation American, (mother is Bolivian and father is Colombian) identity has always interests her and tries to learn more about the cultures she belongs to.

One way she tries to understand her cultures and others is through architecture. She believes that architecture should be a representation of the community in which it is placed. She is interested in designing public spaces (park, parklets, etc.) and working close with communities to have their voice and interest be heard through her designs.

---

San Francisco is a place of many identities and a rich history that is always evolving. All of the different neighborhoods are so diverse and have continued to thrive with the new economy of the city. There is one neighborhood that seems to stay isolated from the benefits of the new economy: Bayview/Hunter's Point District. Once called "Butchertown" and then later becoming the home to the largest shipyard, Bayview has become a predominately black, impoverished neighborhood.

As a new resident of the neighborhood, I wanted to learn more about it and try to understand the identity of the place. Before moving there I knew little about the neighborhood and what I did hear wasn't great. One thing is for certain, the Bayview has a soul. Since the city wasn't going to look after them, the residents had to pick up the slack. In recent years the community has decided to lift from within and started to build public spaces, community gardens and public art. This self-rejuvenation is what excites me about the neighborhood. People here want to go back to saying hi to their neighbors and getting together for BBQS. Living in the Bayview I do feel a sense of community but it just has been overshadowed by all the violence.



The goal of my proposal is to help find and show the Bayview's identity through photographs, found objects in a multi-layered collage mobile. The exterior of the piece is dirty with mud and dirt from the Bayview representing people's misconceptions of the neighborhood that clouds their judgment and it is suppose to make a statement about the toxic the land that the neighborhood sits in because of the Naval Radiological Defense Laboratory that was in the area for years testing radioactive material. Inside the collage are going to be photographs, interviews, and found objects that demonstrates a more realistic view of this multi-faceted community.





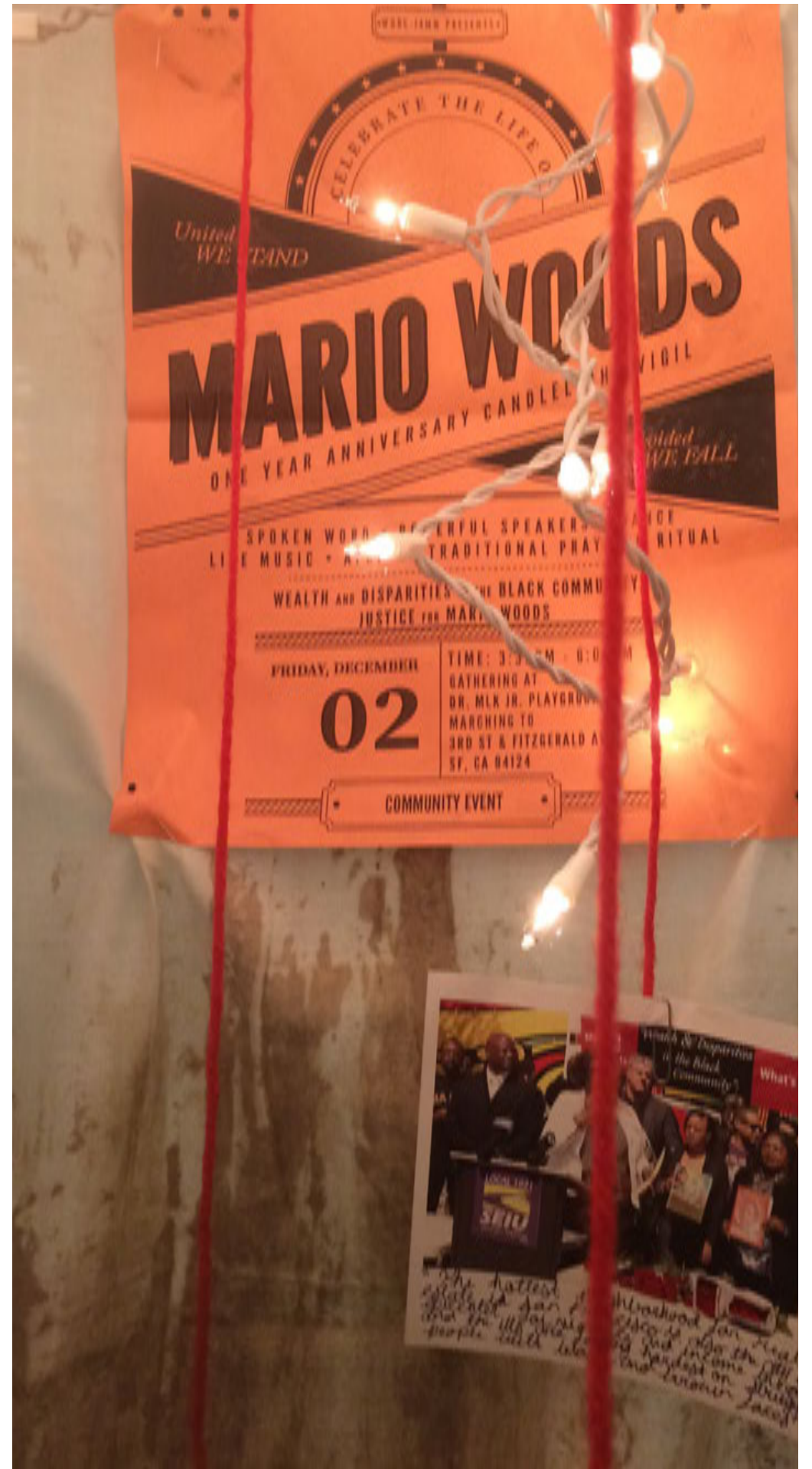

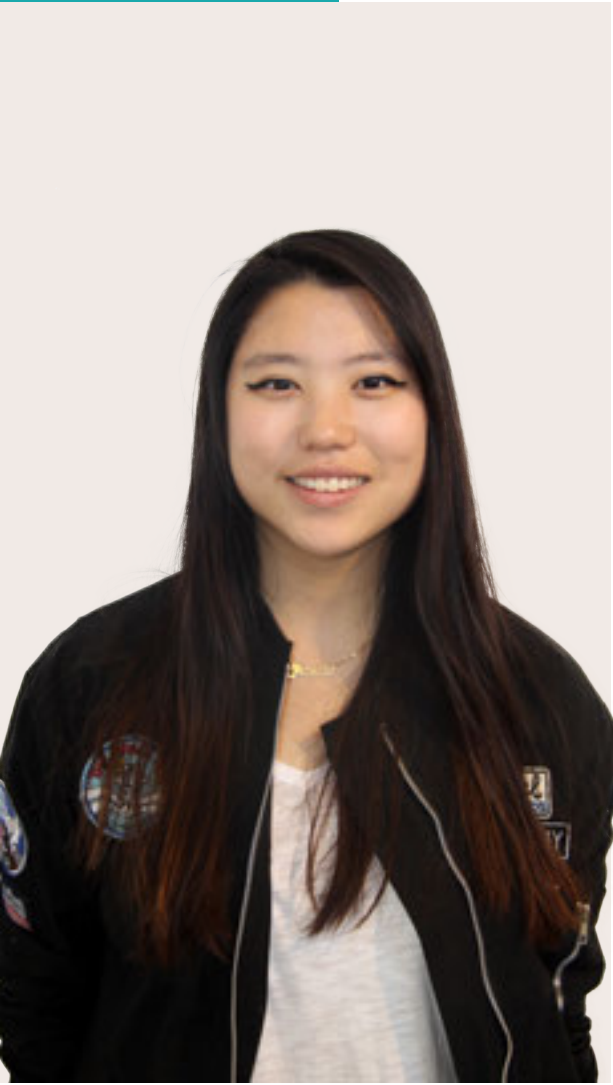

# Recreate

## Jasmine Park

*Illustration*

Jasmine Park is an Illustration student at California College of the Arts. She is an ambitious, passionate, and perseverant Illustrator seeking to further develop skills through working, adapting, and growing in a professional artistic environment. Her works range from technical and gestural drawings to more narrative artworks. Currently, her works focus on product and interactive illustration, in an effort to enhance communication.

---

For my project, I created an interactive structure that focuses on gentrification, specifically in Japan town and the Western Addition of San Francisco. To be more specific, this massive central structure is the renown Fillmore Center, that lies in the intersection of Fillmore and O'Farrell. Although this massive structure is very elegant and well built, it does not suit the environment it is in, and most importantly, does not give a clear sense of history and culture the neighborhood originally intended for. There are many desires, and what people

believe must be preserved of the treasured history, but little do the urban planners know that what people want and need are not the apartment, but merely, a structure of other intent.

Japan town, also originally known as the neighborhood, Nihonmachi, is one mile west of Union Square. Though the area went through many changes in the introduction of new structures, the purpose of the area remained the same: to keep its culture.

This laser cut, three-dimensional structure of the Fillmore Center acknowledges the civic output through the various Velcro-ed icons, with which individuals would be able to place onto the exterior of the model. The isolated world, portrayed through the bland floor plan inside the model, contrasts to the colorful, civic consideration of what this building should be or should have been.

The Fillmore Center seems very out of place with its newly modernized high rise building as compared to the old run down buildings surrounding the area. Although the neighborhood buildings are worn down, the culture and history still remain. The introduction of the Fillmore Center in its website may seem very appealing, but many







# Multifunctional Playground for Unaccompanied Children

## Carmen Jiawen Hu

*Interior Design*

Born in China, lived in Hong Kong and Vancouver before, Carmen Hu is currently a senior college student working toward a Bachelor of Arts with a focus in Interior Design at California College of the Arts based in San Francisco. Her interest in the field includes space planning, material finishes, as well as computer rendering. She is most passionate about commercial and hospitality design.

---

The group that I work with is Catholic Charities, a nonprofit organization that offers supports to low income families, refugees, immigrants, youths and elders, as well as unaccompanied minors. Over the past two years, Catholic Charities had filed more than 100 cases of unaccompanied minors, helping these children to achieve permanent status in United States. Most of them had escaped from their home countries so they are often traumatized from abuse, persecution, or exploitation. Through interviewing people working at Catholic Charities, I found out that what these kids really need is in fact, financial assistance from public, food and clothing, medical care, and mental health counseling. Most of all, they need our compassion and care that respects both their dignity and their status as children. While being a student I cannot really provide financial support to the minors, I designed a creative sport facility that may help in assisting mental and physical supports.

The Child Development Center of Catholic Charities is located on Treasure Island. The center has a wide outdoor space, but the only



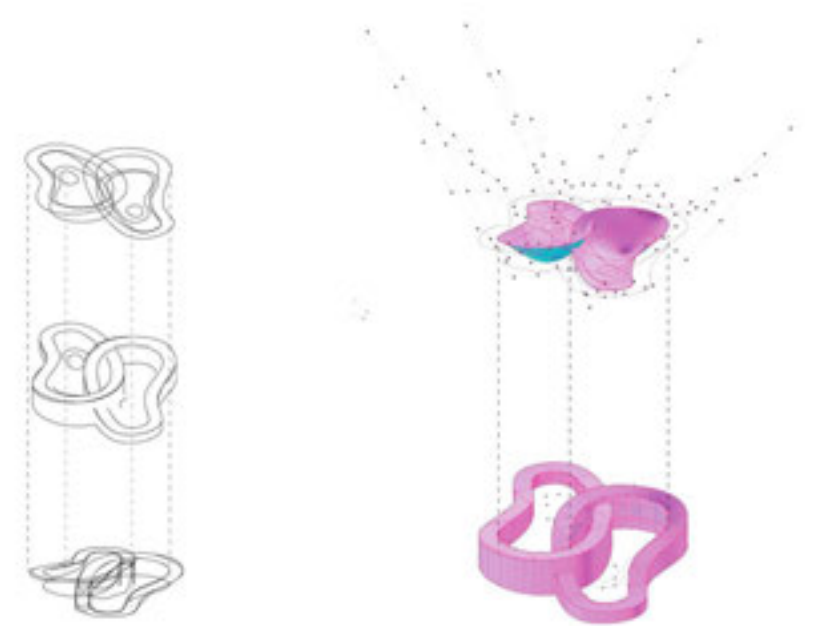
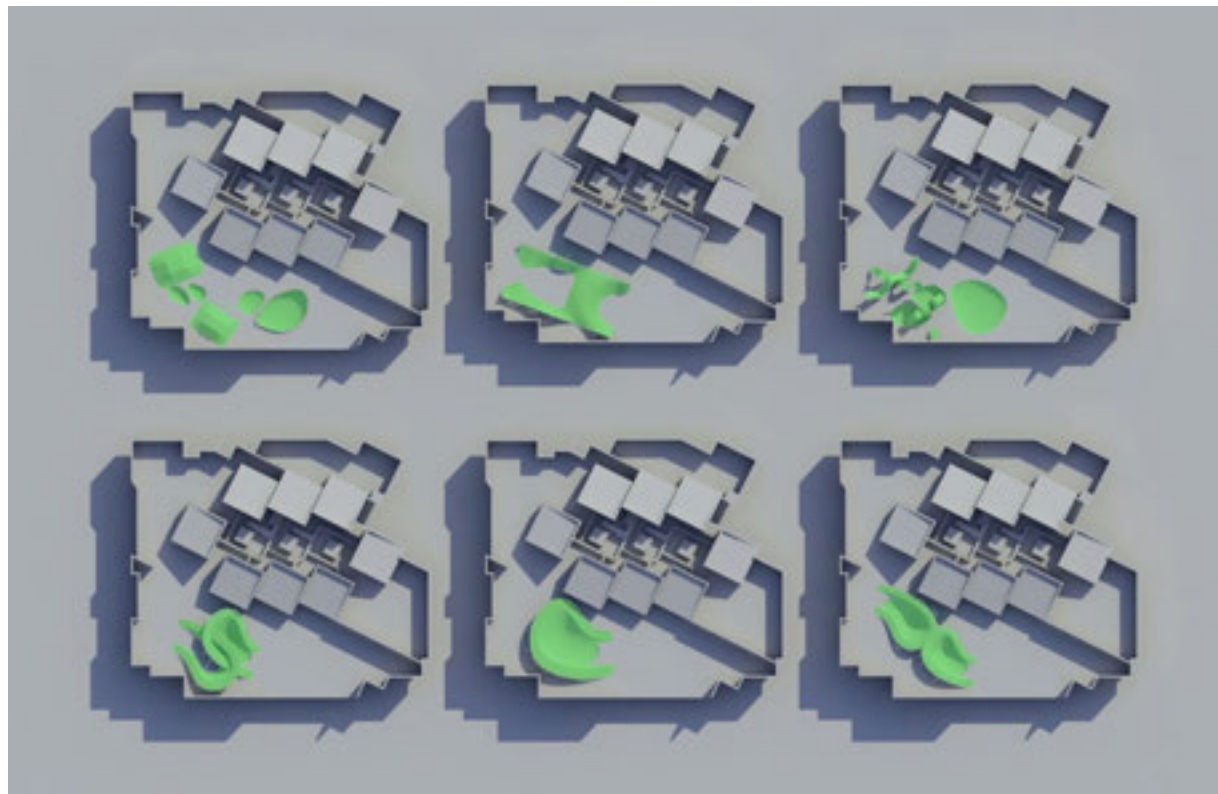

facility there is a slide and a swing. I want to fully use up the space, at the same time leaving an small area for gatherings to happen. The purpose of this outdoor sport facility is to create a multifunctional playground with no boundaries so that children can interact easily. My design was inspired from skate parks and the hierarchy would be a large concrete structure, placed in the open area with different functions on each side.

The facility is mainly designed for children around 15-17 years old, (since they are the majority of accompanied minors) but would still be safe for younger kids to hang around. The major material will be concrete, and the rock climbing area with be covered with rubber flooring. Research shows that an increase amount of exercise could have a big impact on comforting unaccompanied children in a psychological level. Therefore, I am hoping to expand and encourage outdoor activity through the spectrum of space planning in this case. The project would hopefully help unaccompanied children re-establish trust with people by connecting with others through sports.

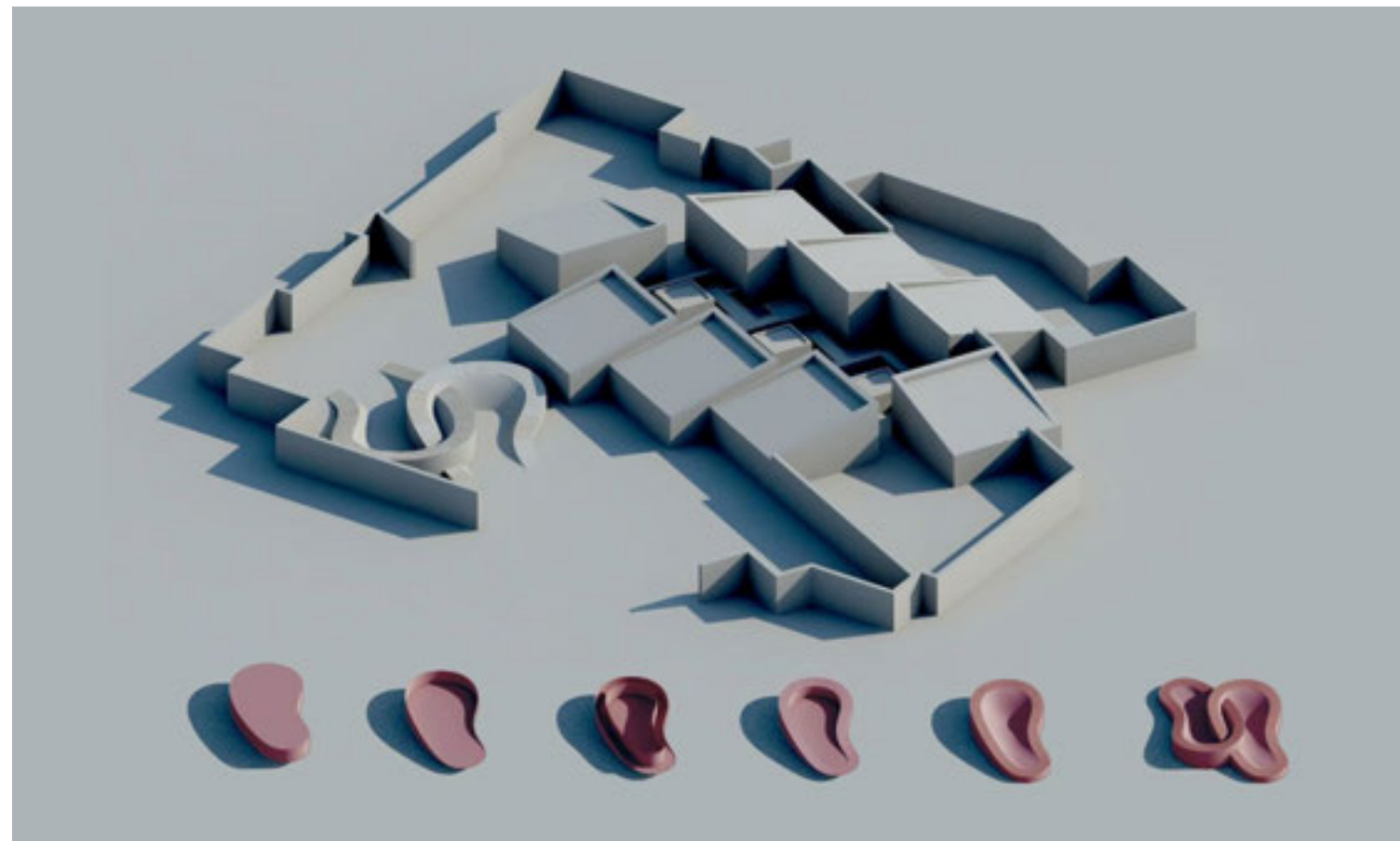

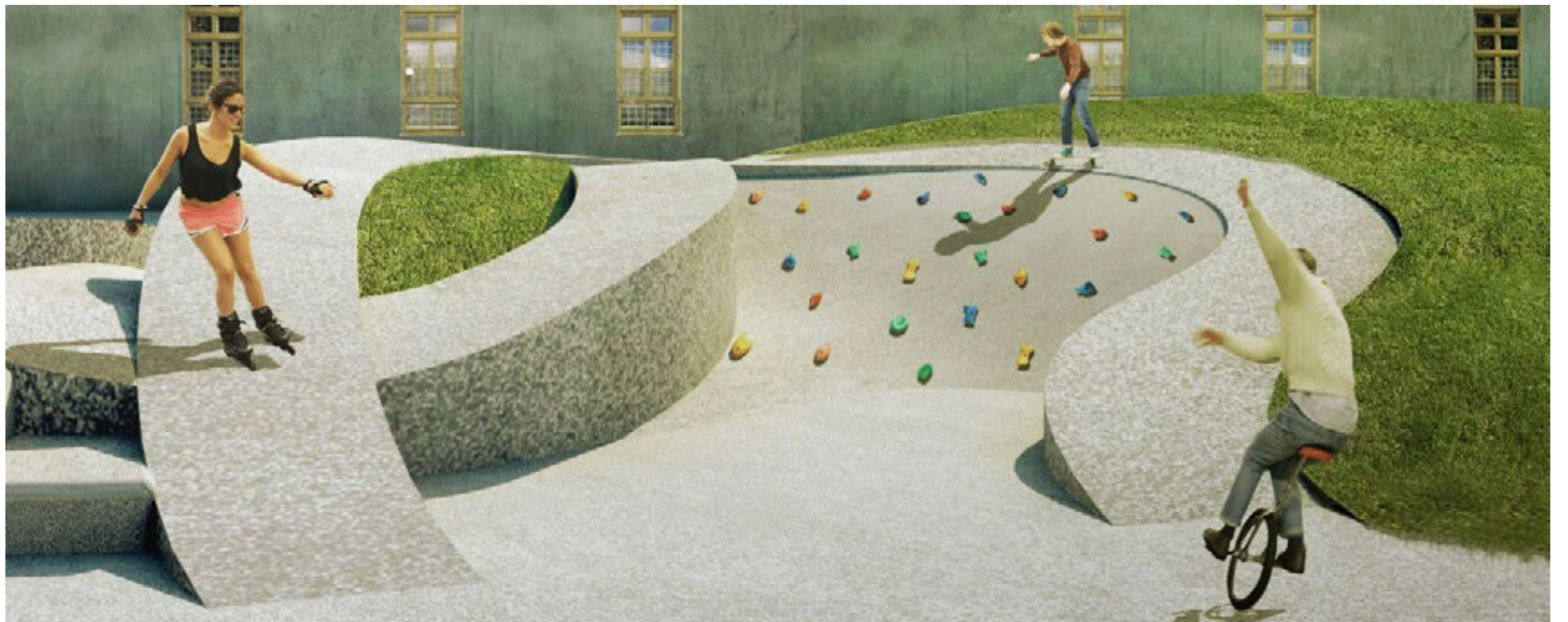



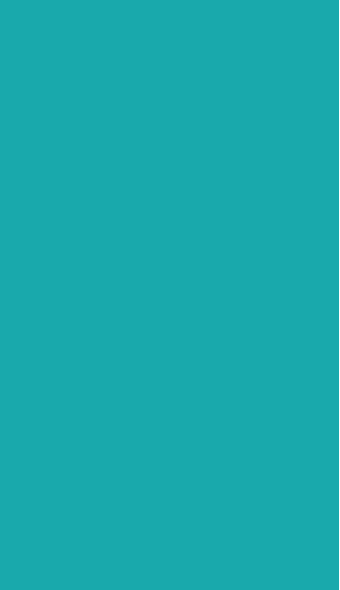

# The Cake

## Dominique Leal

*Painting & Drawing*

Dominique is a senior in the Painting and Drawing department at California College of the Arts. She has always enjoyed the practice of painting since she was a little girl. Dominique also loves to travel and has spent much time backpacking through Europe. Many adventures include visiting museums, meeting new people, and trying new types of food. On her free time she likes hiking and attending music festivals with friends and families. In the future she hope to explore more places of the world while still maintaining her passion for the arts.

---

Through my art development process, it is essential to access my most basic level of self by unpacking my own identity crisis of my past, present, and future. I accumulate my inspiration from personal self-discovery which allows me to venture farther into my being and pick out the importance I deem fit. Finding a personal topic and subject to work with was a very difficult task when needing to decide where I fall in the natural world. I have chosen Family Lineage and Hybrid (Identity) to help further investigate myself as a person and an artist. For such topics, it becomes crucial to base off a landscape in which you have grown and developed in or drawn a deep-rooted connection from. Last Fall I started my path of self-discovery through the creation of cakes and the fascination I have with the idea of being celebrated worldly for the pure act of being born into this world. For me, I have chosen to depict a two-tiered sculptural birthday cake traditional to my self-identity process of understanding what it means to be born into the world. Questions that I considered in my process; Where do we come from? What are we meant to be? What does my past mean? From the moment of our birth, that is when our history

begins and that day becomes marked. I have been able to dig in further by technique and use of color with added broken mirrors into the texture. Through reflection of the broken mirrors, one will be able to look at themselves and conjure a time or memory of their own that reminds them of a piece of their own Identity. By creating a sculptural multi-layered process I have then grown a personal attachment and self-growth as this is a time dependent process. Through this project I hope to have learned a bit more about myself as a person and what it means to be a vessel in this world.







Happy  
Birthday!

# Syrian War: The Numb War

**Edward Lee**

*Illustration*

Senior Illustrator at CCA. Ambitious Korean American designer with 5+ years of experience for insight driven concepts and storytelling. Studied the professional makings of image making and editorial productions. Making design into reality through achieving a logical and cohesive message through both digital and physical mediums. Detail oriented, but well focused on the bigger picture.

---

My project reflects on the issues regarding the war on Syria and how the war is misrepresented to Americans through the folly of Western media. This project also identifies the position of Americans when associating war through media, the Internet, and other sources of social networking. This project will emphasize the American relationship between media incorporated knowledge and the hard-cold reality of the Syrian war. It is a confrontation of gullible Americans believing everything that they read or hear through Western media and allowing themselves to believe that they understand the full story and reality of the war. The truth of the matter is that, Americans who have never step foot on Syrian ground know only a glimpse of the violence and devastation that is happening in the Middle East. Yet Americans become easily outraged when they view images, videos, or any other media content regarding the Syrian battles. They are easily manipulated and also easily change their attitudes and sentiments. People who can only see the war through a third party simply do not care. Rather they are only feeding themselves with doses of the war as if they are numbing themselves of the



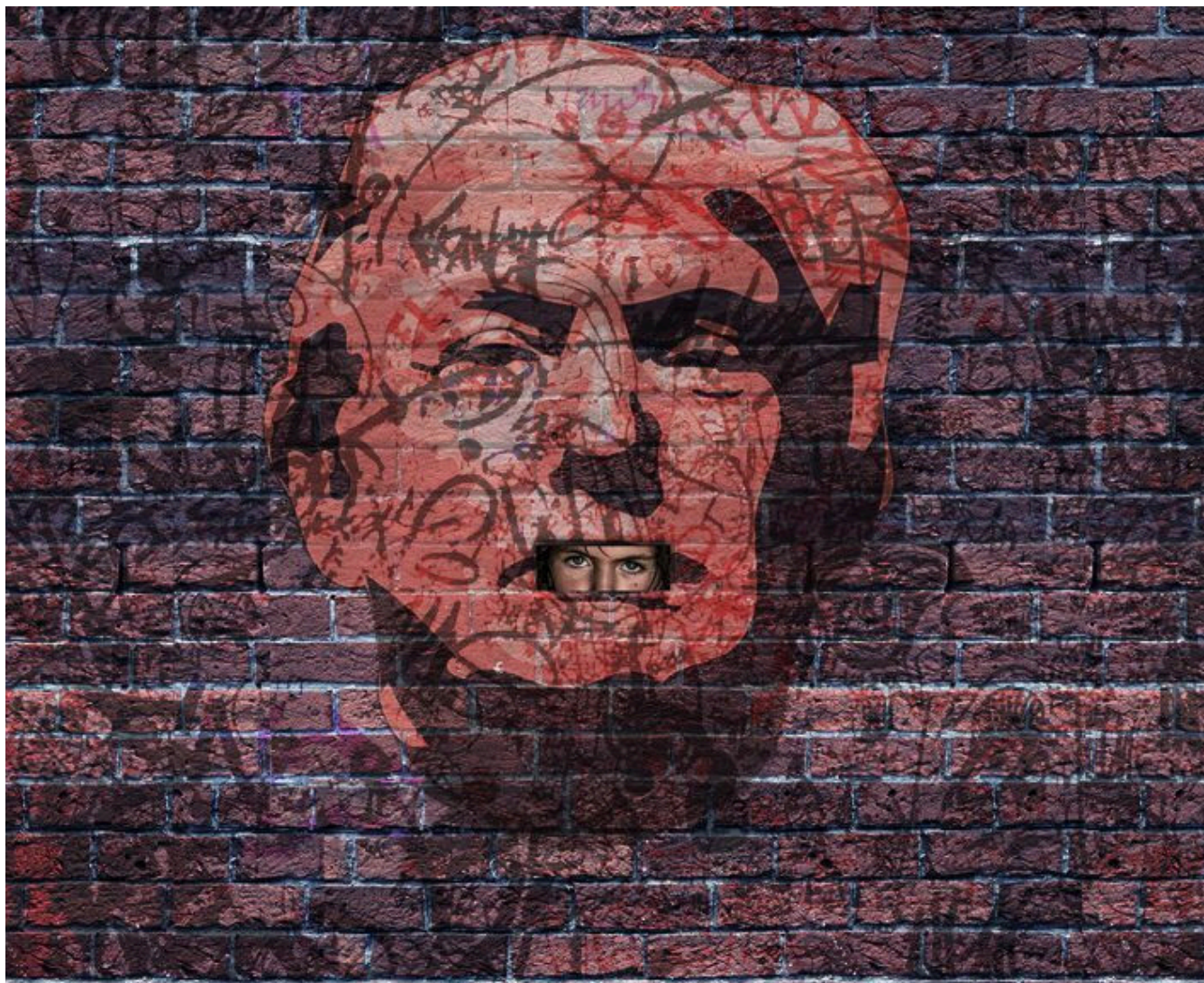

whole ongoing situation. The media is numbing our perspective on war because we are simply viewing it way too much on smaller increments of the progression of the Syrian war. If people who are not affected by war are truly outraged by the war, we would all be globally funding and fighting side by side to stop the war. These emotions and movements we feel about the war have no real value when it comes to having the courage to take these problems as our own. The one truth is that the Syrian war is a global problem that must be stopped. However, how many of us actually care enough to sacrifice ourselves to commit to take this problem as a number one priority? Americans are simply protected and too prideful to admit that they are doing absolutely nothing about the war no matter how many protests they have in America. Western media on War is feeding us what we want to see, and is consistently fueled by easily affected Americans and their fake ideals of believing that their opinions are more important than their actions. Thus, my project will reflect on these ideas through artworks of various mediums and portray the numbing of war through media.





# Hybridity

## Morgen Sellier

*Individualized*

Morgen Sellier is an individualized student at California College of the Arts, focusing on illustration, industrial design, and sculpture. Her art is informed by her status as a mixed-race, queer woman, and has a strong focus on the inclusion of marginalized cultures. She loves hearing and telling stories.

---

I'm focusing on the politics of visibility for people of hybrid identities. These people belong to two or more ethnic and/or cultural groups, and while there are many who identify as a hybrid, there is little talk or visibility about them. This can lead to exclusion from both groups that make up their whole, shame for not being 'enough' of something, and a struggle to make others aware of one's whole truth of reality. Through my work, I intend to shed more light on the existence of hybrid identities and how they are expressed and viewed.

To do this, I have made masks for myself and a friend. These masks include symbols of the groups that make up the subject's identity, blended

together into a harmonious whole. The connotations of these symbols - positive or negative - depend on our experiences.

Aesthetically, I reference cut paper artwork. The transparency affect achieved through this technique allows for a second read of the work, tempting the viewer with glances of the person behind the mask. The one-dimensional aspect of the masks also furthers the idea that someone is more than just a singular aspect of their identity, and that to truly know a person, you must take them as the sum of their parts.

---



I'm Iraqi, German, Mexican, and Trinidadian, and in my family we often joke that my sister and I are made from all four corners of the world. I see myself as a third-generation child of immigrants first, an American second—it's hard to fit in completely with a white majority when your family speaks in a pidgin of Arabic, German, and English in one house, Spanish flies in the second, and there's a multitude of recipes from all over in both.

I'm lucky. My mixed race has always been celebrated within my family. I've always been proud of who I am, glad to be able to move between four cultures with relative ease, happily playing in the intersection of all. I am at once a blend of each group and noticeably part of whichever side of the family is with us at any given moment. I have this person's eyes, that one's nose, and I know bits and pieces of everyone's history. To look at me is to see four timelines meeting together.

As I grew up learning about American history and politics in school, at home I would hear about the civilization of the Maya, the cultural richness of Iraq, the trials of WWII in Germany. My lineage is an old one, traceable on one side to the 1400s, and I've gotten used to carrying history around. I know enough to start to slide into a group of through-and-through Iraqis—or Germans—or Chicanos—or Trinis—just enough to be valid in their eyes. I may be a different-looking beast, but I'm familiar enough. Just enough not to be tossed out, but welcomed into the circle. Just enough for me to want to keep learning. Just enough for me to be able to.







I'm Chinese American, I have Chinese parents and I was born in the United States of America and have grown up learning to be "American" versus being Chinese. But because of my family's ties to Chinese culture I also learned growing up eating mostly Chinese food, celebrating Chinese holidays, and participating in Chinese versions of certain ceremonies (funerals/weddings). So I'm extremely American yet I follow a lot of Chinese traditions and ideologies.

However, I have a hard time fitting in with a lot of people who are Chinese American because most of them speak and have a lot of working knowledge of Chinese. I don't really speak, read, write, or know much about Chinese history or my family's history. Because I can't speak Chinese, a lot of times I'm met with people who are Chinese who look down on me for not knowing the language. Also, when my family is over I'm often teased for not understanding certain jokes because it's a pun in Chinese or even if I try to pronounce certain words in Chinese I get made fun of for not saying it right. Some people who aren't Chinese would often ask me what Asian I am, and after that ask me to say something in Chinese, but I don't know anything so I can't give them what they want. So I usually lie and say I'm Japanese instead to get them off my back. I say Japanese more confidently because I've been immersed in Japanese culture since I was in middle school being interested in anime. My interest in anime has also gotten me interested in the actual culture and history of Japan and the language itself, so I've studied many parts of it and have a general working knowledge of it.

So I'm fake Japanese, Chinese American.

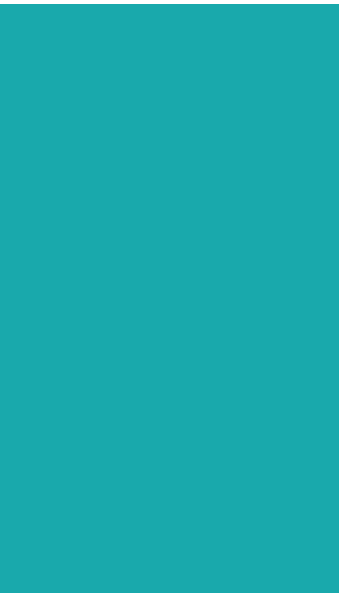

# Ritual Place

## Artem Struyanskiy

*Painting & Drawing*

Artem Struyanskiy is a Russian artist currently pursuing his BFA in Painting/Drawing at the California College of the Arts. His works deal with notions of trace, relations between space and place, intimacy and human relationships. Artem truly believes that Art is one of the humanity's most incredible gifts.

---

“One question that has always intrigued me is what happens to demonic beings when immigrants move from their homelands. Irish-Americans remember the fairies, Norwegian-Americans the nisser, Greek-Americans the vrykólakas, but only in relation to the events remembered in the old country. When once I asked why such demons are not seen in America, my informants giggled confusedly and said ‘They’re scared to pass the ocean, it’s too far,’ pointing out that Christ and the apostles never came to America.”

The concept of cultural interweaving is not something new for the 21st century. Today we are more when ever are able to travel on a long distances cross the borders of hundreds countries. United States is an example of a country whose cultural heritage is being created from the scratch by devouring and recycling the cultures of all the people who came and stayed. Not to mention the fact that with invention and rapid development of the Internet one can learn about almost any existing culture without going outside.

Our civilization reached the point that not knowing about certain religions or cultures is simply considered to be a lack of education. However, even though it is incredible and exiting to learn about new traditions, ceremonies and beliefs which stand outside of our own nationalities, it is hard to miss the fact that any informational exchange, especially verbal, tend to turn into a broken phone. Some parts are being missed others left out as something unnecessary or presumably understandable without mentioning. In the end we get this oversimplified or completely different cultural aspects.

My interest lies exactly in discovering this “new” metamorphosed cultures. Exploring San Francisco I am determent to find ritual places; places which stand out from the usual image of the city, sometimes without any specific reason, or places which became part of the city and masked its extraordinariness. I will try to accumulate all these places in forms of drawing and painting to create a visual ritual map of San Francisco.

I believe this project reveals the nature of United States. It's desire to create new images and myths about cultures since it doesn't fully acquired one of it's own.

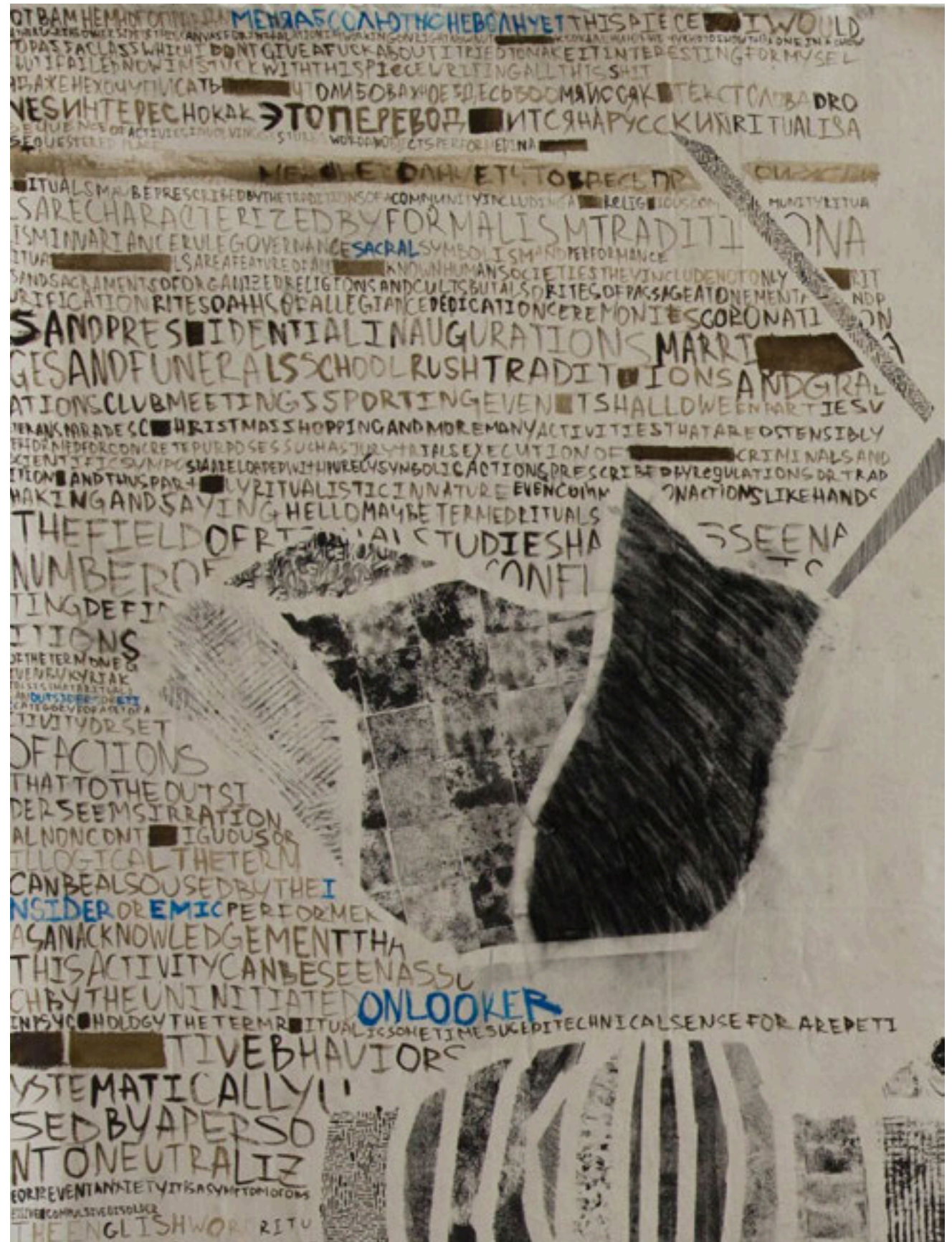



ПАМ

ВЛЯЕТС

НО ПАМ  
А БО БО  
С А С Х  
К Ч У А

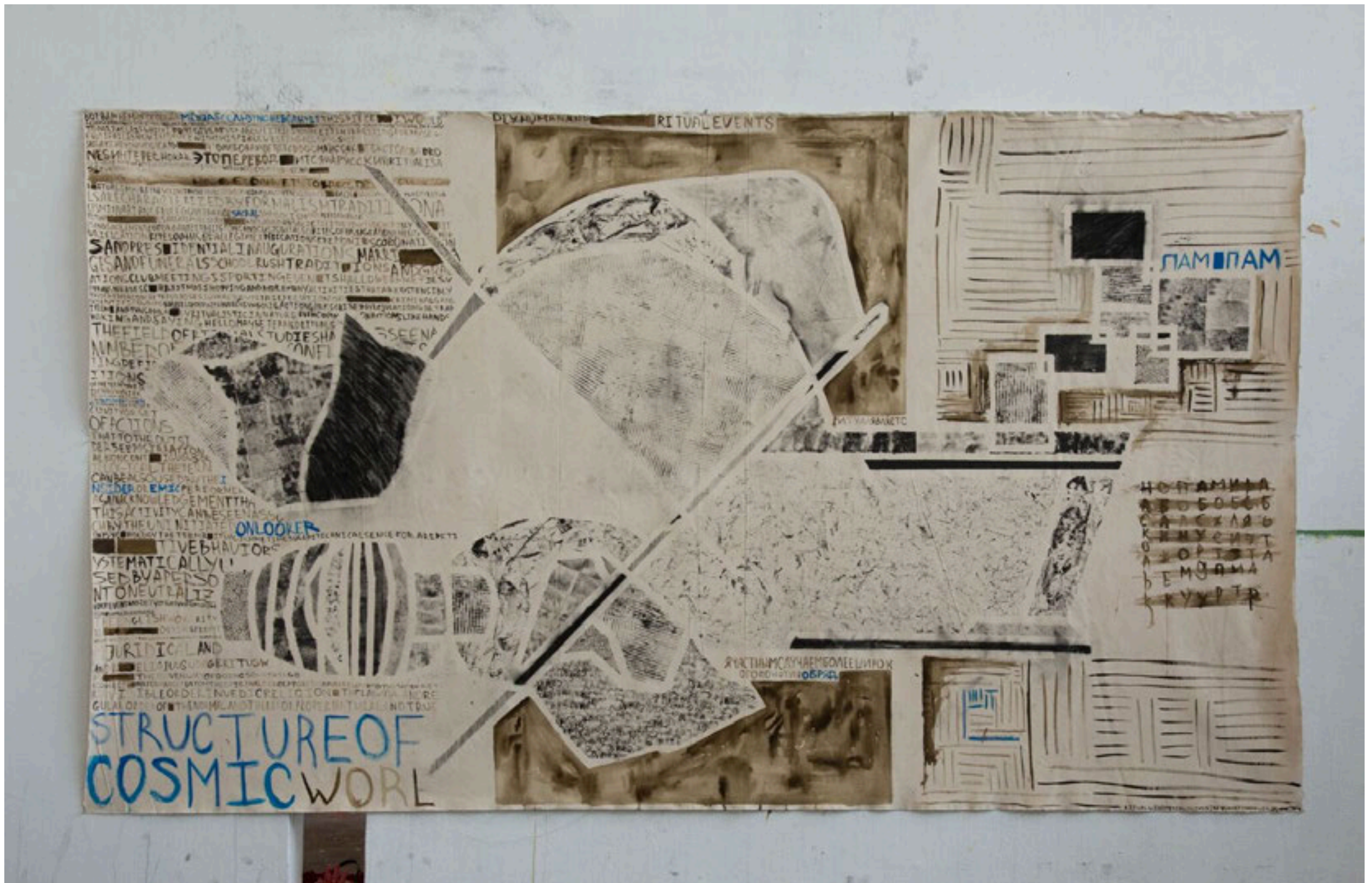

## Gentrification of San Francisco's Mission District

### Kitty Teng

*Painting & Drawing*

Kitty is a Senior Painting and Drawing major at the California College of the Arts. She is from Taiwan, Taipei. She is interested in painting abstract landscapes and observing different environments to find inspirations. She likes to work with oil and acrylic paint, and gloss medium. She is also interested in film and Graphic Design.

---

Over the past years, San Francisco Mission District has experienced a great deal of change. The Mission district has been undergoing a gentrification process in which redevelopment, lack of rental units due to condominium conversion have left many low income residents homeless. Gentrification is a complex process in which more thorough investigations are needed to fully understand how it impacts the residents of changing communities. I will research the Latino community of San Francisco, this project aims to contribute to a better understanding of how gentrification affects long-term residents. I will start my project by having a better understanding of the situation that the residence in the Mission district are facing. I have found an organization called the Causa Justa in the Mission District that deals with these kind of issues. They not only focus on the issue of gentrification. They also, ensure that all people, regardless of immigration status, have a right to work. I contacted the organization, they told me they are working on a project called the Housing Rights Campaign. This work focused on fighting gentrification, they focused on policies, direct action and coalition work to fight for resident decision



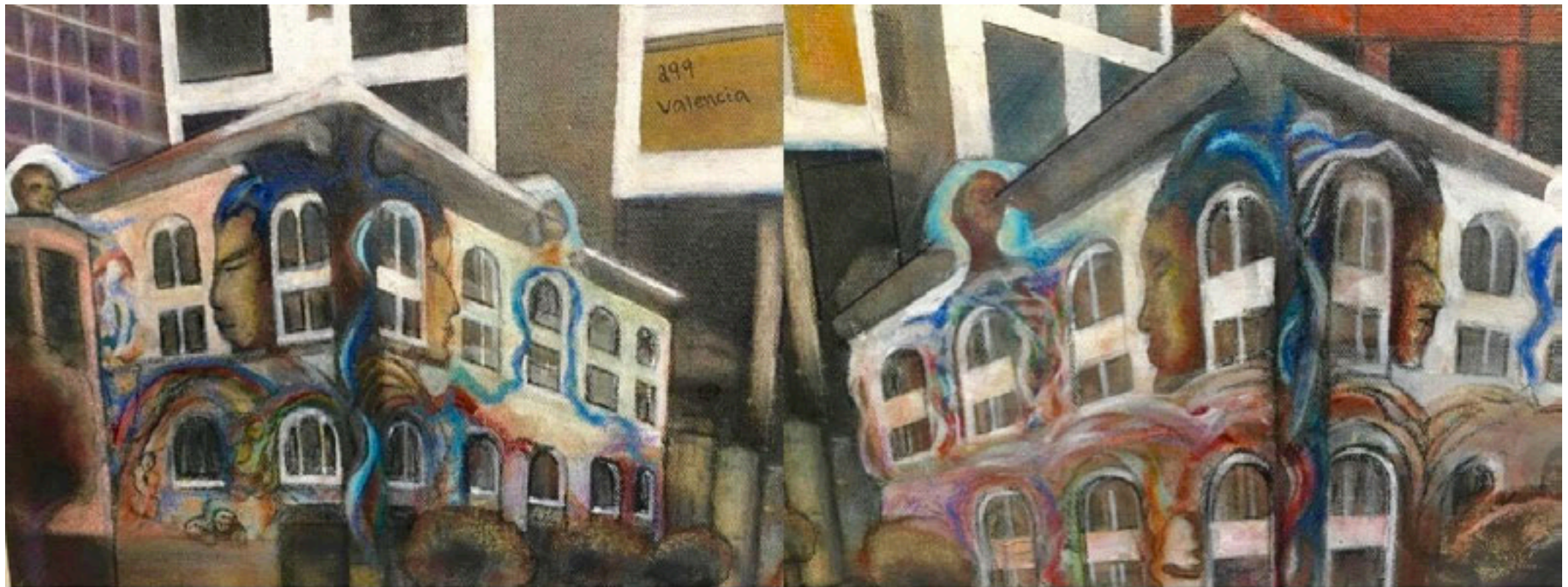

making regarding development and using the government to prioritize housing and tenants' rights.

Therefore, I have come up with an idea of doing a painting for Causa Justa. The painting is going to be about the old mission vs the new mission (developing mission district). This painting will be painted with pastel and acrylic, 16x20 inches. I want to make this painting as a way to support this project and this organization. I am also making 2 frames comparing the foods in the Mission district. Using the same idea old verses. new, to compare the traditional restaurants and the newly developed restaurants in the mission district. Causa Justa told me they are looking for people that could get more involve with this situation. They need people to support them, and help all the people that are facing a chance of getting thrown out by their own home. I feel pretty related when it comes to gentrification, because I used to live in the Mission district as well, and was forced to move out due to rent prices. My intention by doing this project, I hope by doing this, more people can be more aware of the issues (gentrification) in the Mission District or even worldwide, and to support those who are in need.





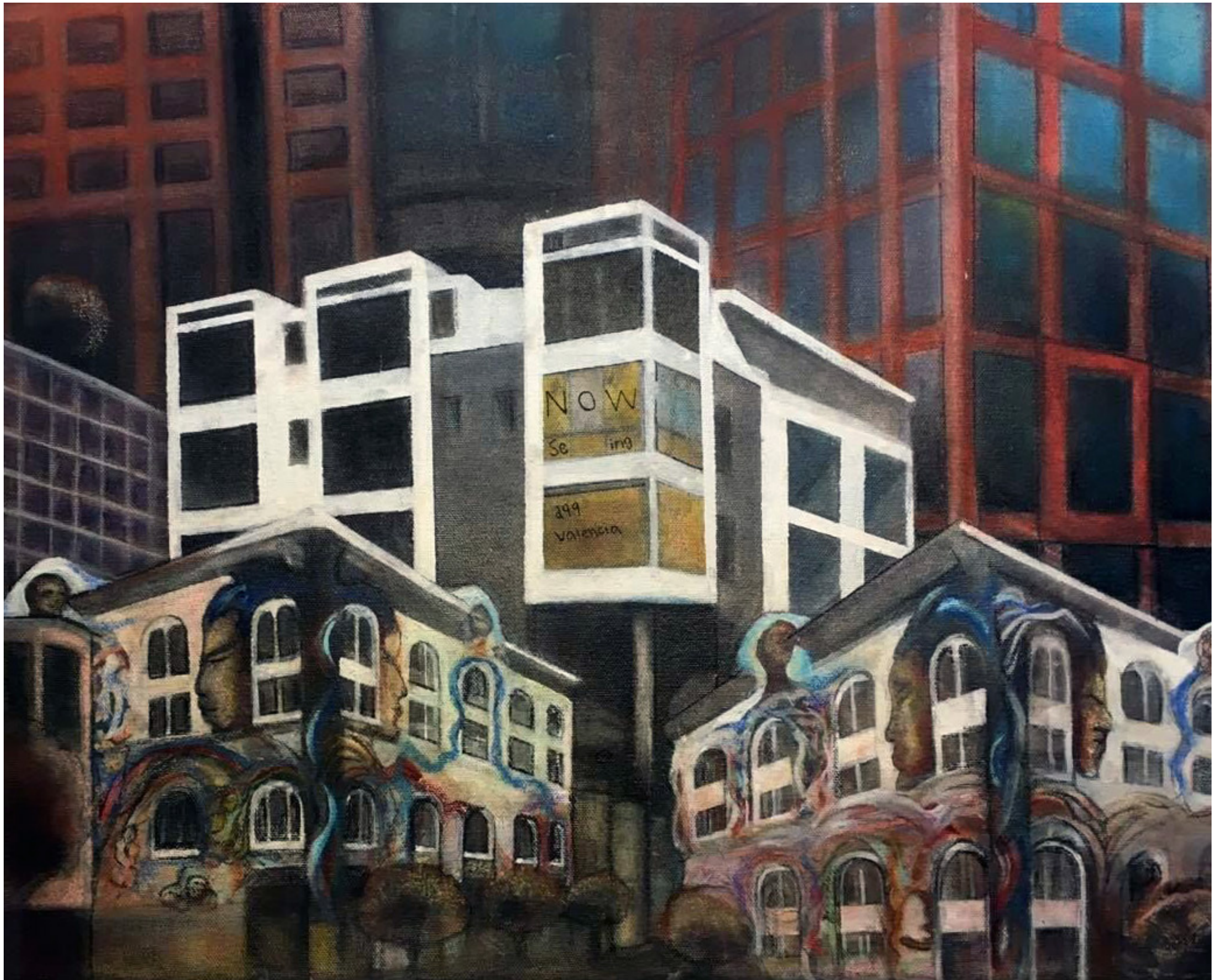

# Immigrant[e]

## Joaquin Tobar Martinez

*Architecture*

Originally from San Salvador, Joaquin has been always interested in Art, History and Architecture. As a native from El Salvador, Joaquin has been involved in sports since high school. Reaching a high performance level, he has competed at international events with the goal to qualify as the first Salvadoran fencer at the Olympic Games. This opportunity to represent his country in events around the world has become a passion linked to the direct experience of culture. Joaquin left El Salvador to continue with the Architecture program in San Francisco while his family still lives in San Salvador. His interests for research are linked to the city, urban form, and the rehabilitation of his hometown in San Salvador at the functional, economic and cultural level.

---

Nowadays, we are drowned in electronic information, but how much are we able to appreciate and understand the reasons and backgrounds for immigrants adapting in the cities of California? San Francisco maintains a huge number

of immigrants from all over Latin America. In recent years, the number of immigrants from all over Central America has increased rapidly, especially children and women. Some immigrants flee their countries to find a way to sustain their families and to improve their success on the fields they practice as individuals; some of them escape from violence. The personal stories carried within the process of adaptation into a different culture are the core concept for this project. Immigrant-e, is a collection of everyday life images and stories introduced to the public through found objects that host shared contents.

### Object Operations

By repurposing an everyday life object, such as the coffee cup and transforming it into a host for the stored information, it becomes a physical representation of the cultural embeddedness. Five to ten different individuals will be asked to participate and share their stories. The cups will be left at different places. No clues given or questions asked, but the documentation of this project will be as important as the user's experience and the decisions made from this random connection.



### Relations with the socio-economic environment

The content which ranges between images, narrations, and short films, are the medium for the social connection between people within the city of San Francisco. The cup acts as a neutral medium that intersects aspects of global economy, politics and culture.

### Installation

The cup will be placed in a public space in San Francisco. Potentially, this will have the condition of found object that later will be discovered. This level of uncertainty is crucial to the project; curiosity is the mediator for the unknown content that will be transferred to personal computers. The information is discovered, the information is consumed.

### Content

Music, poetry, everyday life pictures, pictures at work, pictures from home. Self-portraits, videos, ideas, writing, events, bus rides, train rides, effort, success, happiness, sadness, and hope.



"I've moved to California hoping to help my family to solve the financial deficit that we had after several years fighting my father's disease. He was diagnosed with Leukemia to be exact."

"I've moved to California hoping to help my family to solve the financial deficit that we had after several years fighting my father's disease. He was diagnosed with Leukemia to be exact."

"I've moved to California hoping to help my family to solve the financial deficit that we had after several years fighting my father's disease. He was diagnosed with Leukemia to be exact."



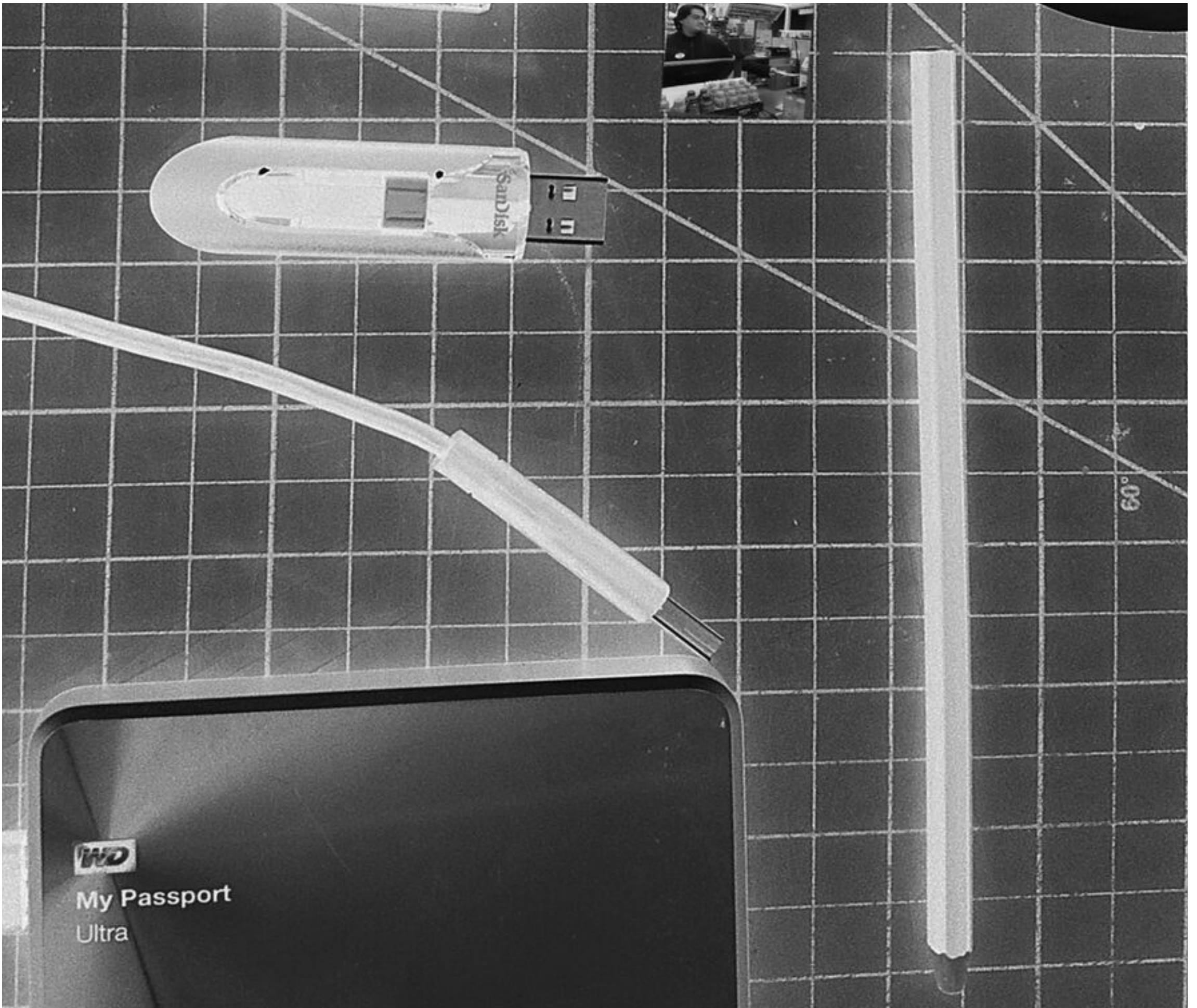

WD

My Passport  
Ultra

Sandisk

60°

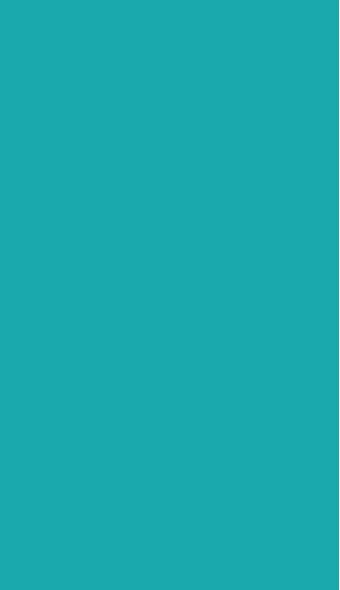

## The Garden at The Henry

### Monica Wongkar

*Interior Design*

Monica Wongkar is pursuing a bachelor's degree in interior design at California College of the Arts, San Francisco. As she pursues her education, she has been given the opportunity to gain valuable experience from professional faculties and her fellow classmates. She is constantly challenging the definition of spaces in the ever evolving world by blending the concept of modernity and simplicity. Monica has keen interest in exploring different spatial effect through manipulation of atmosphere and light by the means of materiality. She seeks to use the inherent potential in a material to developer ideas to the fullest potential.

---

The goal of the project is to create a garden space at the atrium of the Henry Hotel. The Henry Hotel is a Single Resident Occupancy (SRO) managed by Episcopal community service (ECS). Due to increasing rent, families had to move to SRO. Families living in SRO reported that living in SRO had negatively impacted their health due to unsanitary conditions and lead exposure that lead to respiratory problems. This is added to the mental illness, substance abuse, and physical disabilities that were already plaguing most former homeless people.

The atrium is a big space we can transform into a colourful and lively atmosphere, contrasting to the feeling the city sometimes has, I want to bring tranquility and peace to the Hotel, so the residents feel more at home, relaxed, and that they belong to a community.

According to the demographics data I collected from Episcopal community service, I found out the different ethnicities that live in the Henry. Thus, I wanted to propose a vegetable and herb garden with plants from their different cultures so these people could use the herbs/vegetables they grew together in their cooking.



there is an area designated for people to grow anything they like in pots. I decided to designate this space because the Atrium space at the Henry right now contains some plants that belongs to the residents. Second, I designated a living wall system that could hold the different herbs that the community would be able to use in their cooking. Third, is a space designated for growing vined vegetables according to the season. Fourth, is a space designated for light cooking and sharing. This space could also be used by the residents that were enrolled in CHEF (conquering homelessness through employment in food service, a culinary program by the Episcopal community service). This is a chance for residents enrolled in CHEF to share some of their cooking with their neighbors and encourage them to get to know each other.

My hope is that this project could bring warmth and a sense of belonging in the community, and hopefully, could heal those of them suffering from mental problems and abuse.



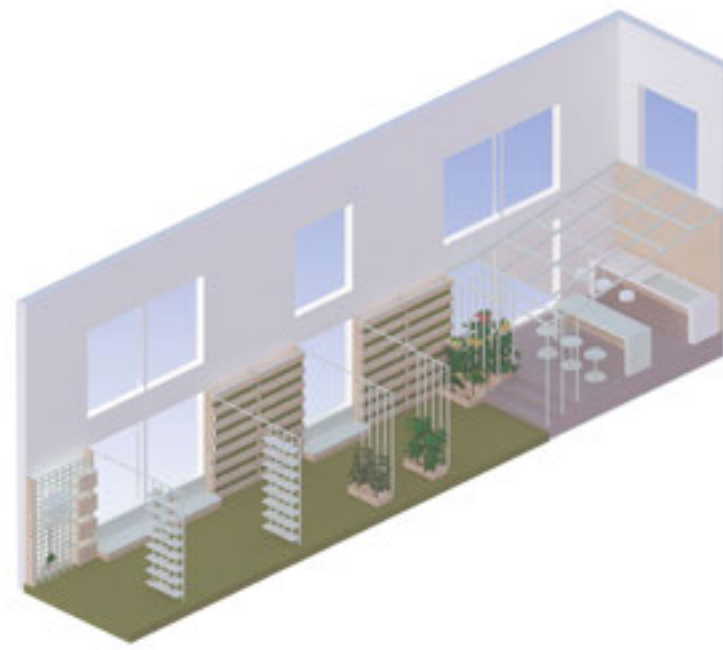

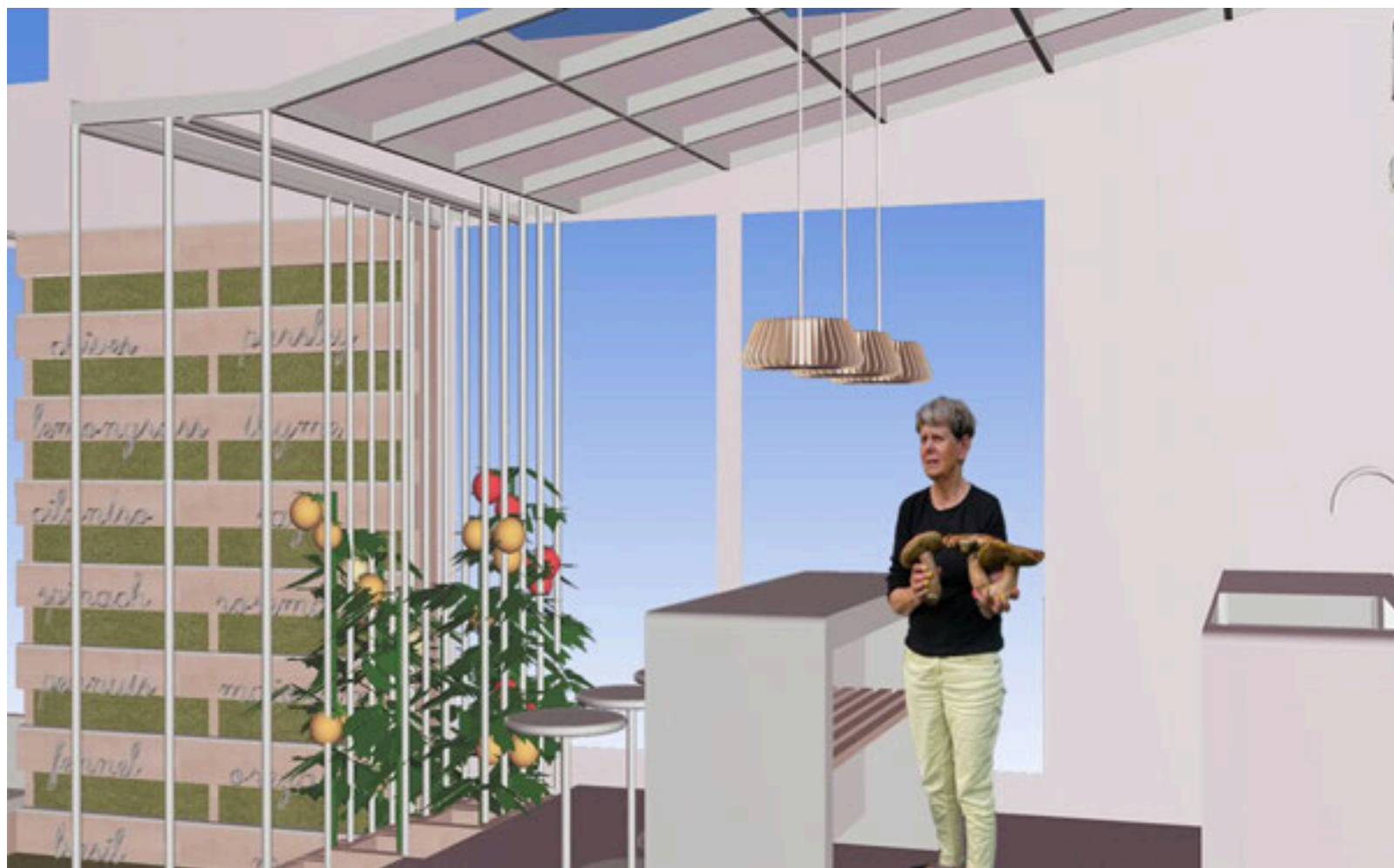

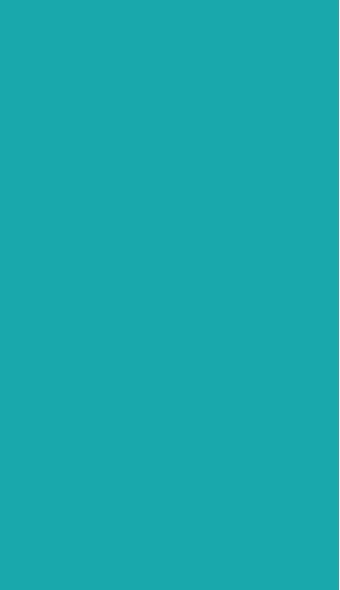

## Mobile Performance Kiosk

### Willie Jigao Wu

*Architecture*

Willie is currently a 4th year architecture student in California College of the Arts. Born and raised in Shenzhen, China, Willie came to San Francisco to study in 2013. He has great interests in public architecture and temporary structures. He has designed several privately owned public projects and movable architectural structures in his studio classes. He is focusing on flexible architecture in public space this semester. He practices digital fabrication, which includes 3D modeling, laser cutting, CNC milling, and 3D printing.

---

Performances bring different people and different cultures together. People with different cultural backgrounds get to know other cultures through performances. Watching performances is also

a great social event. The south of market of San Francisco used to be a very unpopular district. Recently the tech companies flushed into San Francisco bringing the housing price up very quickly. The south of market district suddenly became highly developed with large housing projects. There is very little public space left. The existing public spaces in south of market are very inactivated. The Mobil Performance Kiosks move around the city and deliver public performances in order to activate the public spaces.

The Mobile Performance Kiosk is an urban pop-up structure. It is attached to an automobile to move around the city. The kiosk itself holds different cultural events. The Kiosk consists of a main stage with wheels and all the sitting benches are cladded on it. When the Kiosk is driving on the streets, it attracts attention with all the legs of the benches sticking out. When it stops, the community will help unload the sitting devices and occupy the sitting area around the stage. The Kiosk has flexibility to hold events of different kinds and sizes. Several kiosks can be connected together to become one large stage for big events, or form a market.

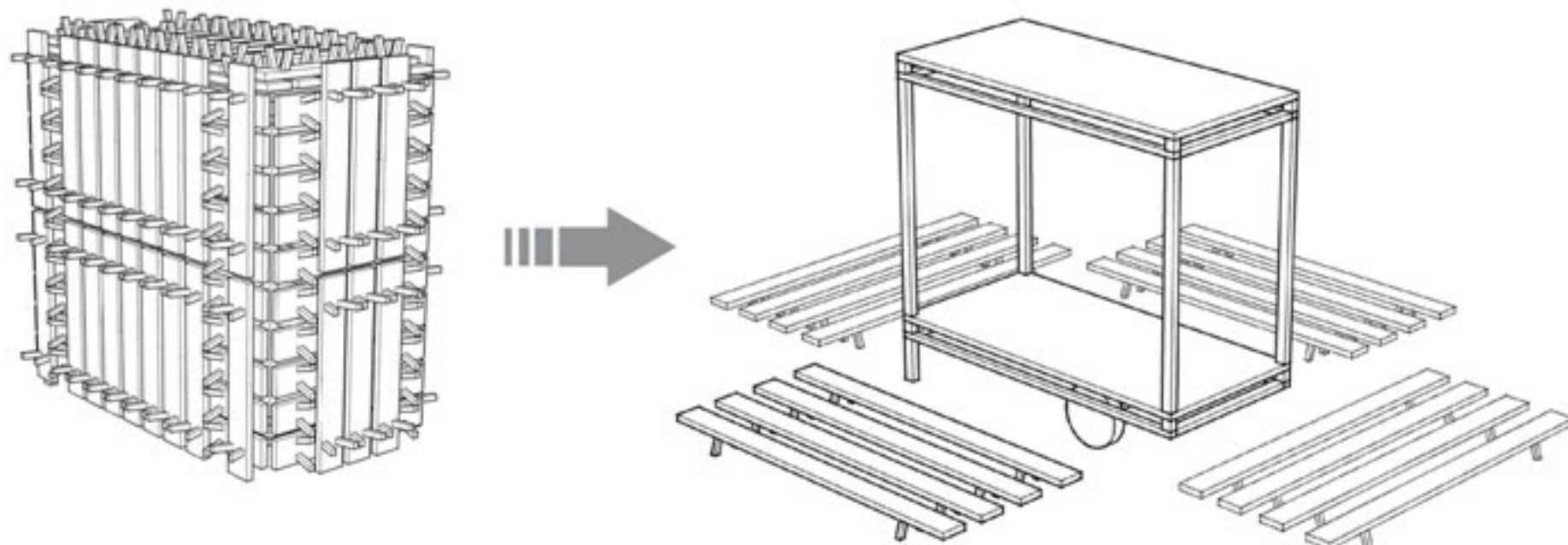

Different theatrical and architectural organizations will cooperate to run the kiosk project. The Kiosk project provides the opportunity for the local theatrical education institutions and local communities to work together. For instance, students from the performing arts department of University of San Francisco will organize performances, and the Kiosks will deliver the performances all over the public parks and plazas in San Francisco. Community theatres can organize different festival events of different cultures to get people in the community together and learn about the customs of different festivals. Wherever the kiosk goes, the performances unfold in the public space and attract people to participate.

The Kiosk is built with all standardized parts and reconfigurable structures. Once the first Kiosk prototype is designed, tested, and worked in the south of market, the detailed instructions of how to build a Kiosk will go on the Internet and people all around the world who have interests in this project can easily get materials and build one of the Kiosk on their own.

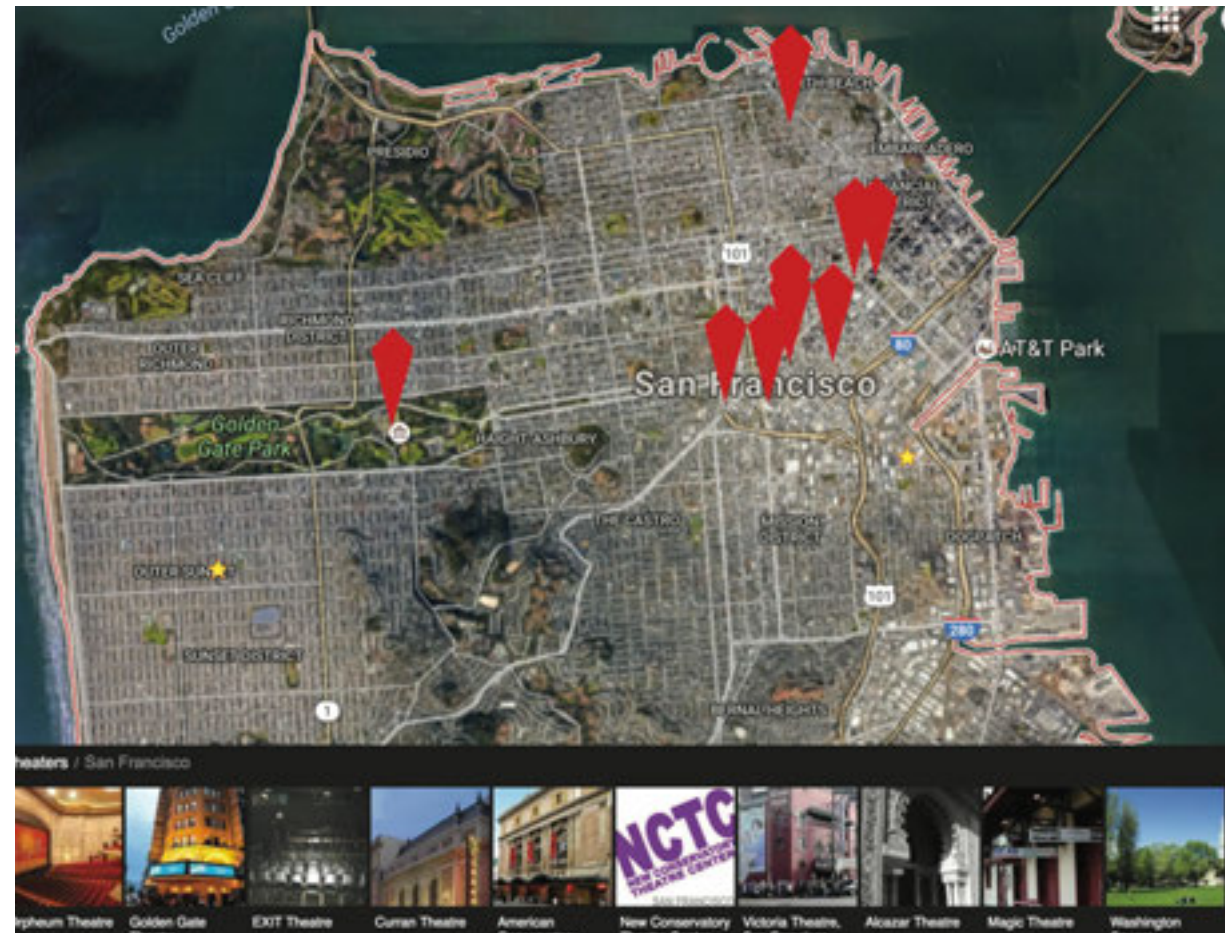

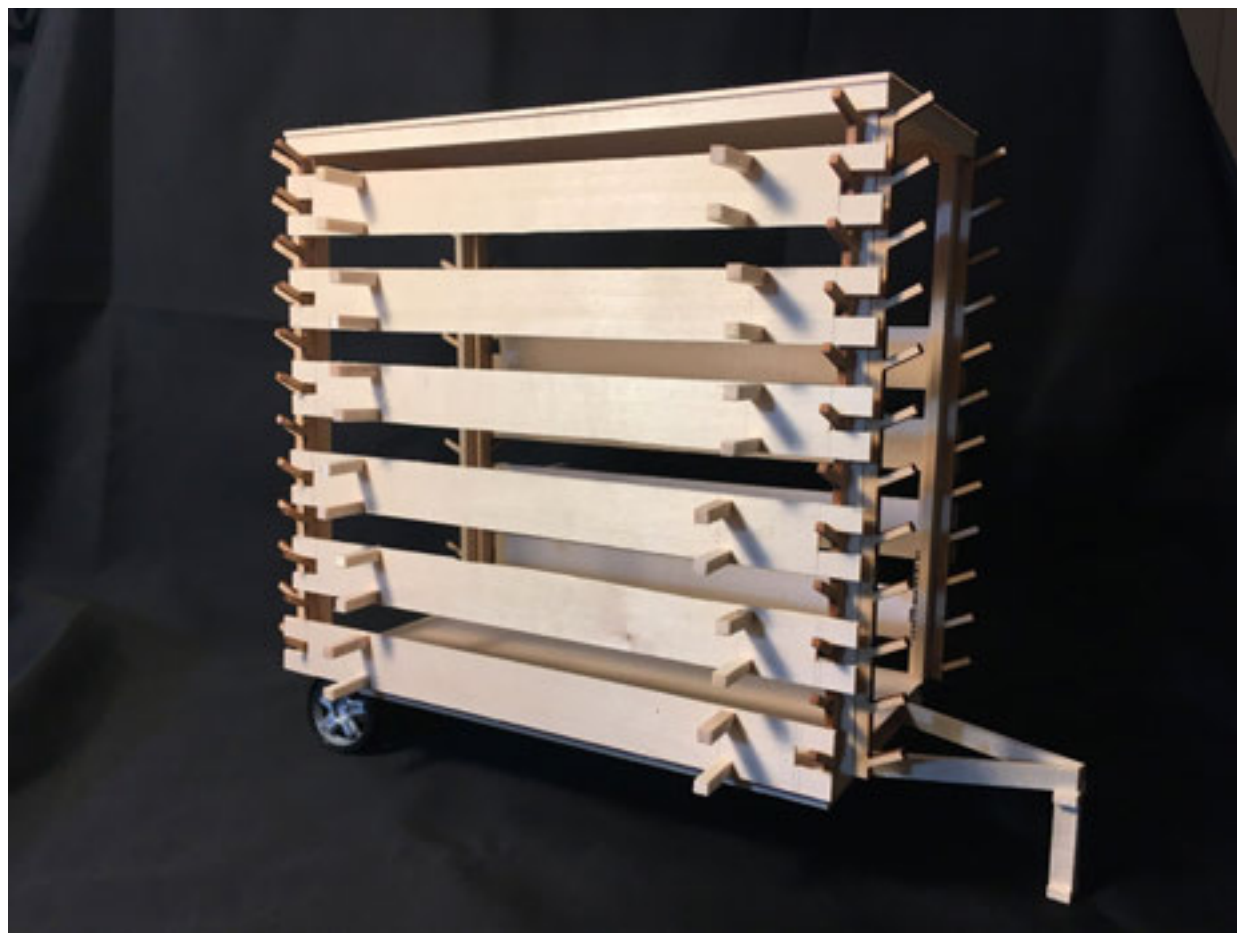



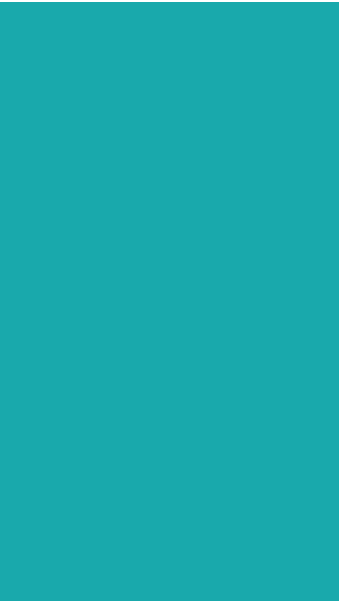

## Portable Shuttle Workshop

ZiHui Alice Xu

*Interior Design*

Alice is a Chinese Canadian Interior Designer currently in her Senior year at the California College of the Arts majored in the Interior Design program. She loves to explore different types of materials as well as how textures could alter the atmosphere of spaces. Alice also loves to travel and see and compare different design styles of from various countries and absorb these knowledge for her use. She design goal is to use these skills to solve any design problems and be able to improve people's everyday life.

---

Inspired by Deleano's tenderloin walking tour, I intend to design portable bus workshops along with a fixed storage location for the homeless people that are living on the street. The bus will be available to purchase or rent for local organizations, charities or companies that would like to give back to the community by giving lectures or open workshops for the homeless people. For example,

Deleano's Academy have been working with local companies such as Twitter, Spotify, Airbnb, Dolby, etc. together to teach the homeless people new skills such as computer science, office documenting, and necessary skills that will help them get a job. Many of these homeless people who have taken the classes have been directly hired by the local companies and have a fresh start.

The storage location could provide extra open space for those homeless people who need a safe place to keep their valuables while they travel around the city to look for jobs and new homes, but also provide a space where they no longer need to pile their belongings on the street. Each bus would have a maximum occupancy of 8-10 people due to the limited space on the bus, and also the amount of attention the teacher needs to give to each student (the homeless). All table tops and chairs will be detachable and easy to install, so each workshop could be arranged in the best study environment possible. The bus would pick up homeless people from different bus stops within the tenderloin district, and drive down to the civic center for an hour to two hours of the workshop, then return to the storage location. This route will be available daily with multiple buses operating at the same time, and a weekly bus workshop schedule in the storage place where homeless people could get easy access to and know before hand about what type of workshop or lecture they could attend during the week.

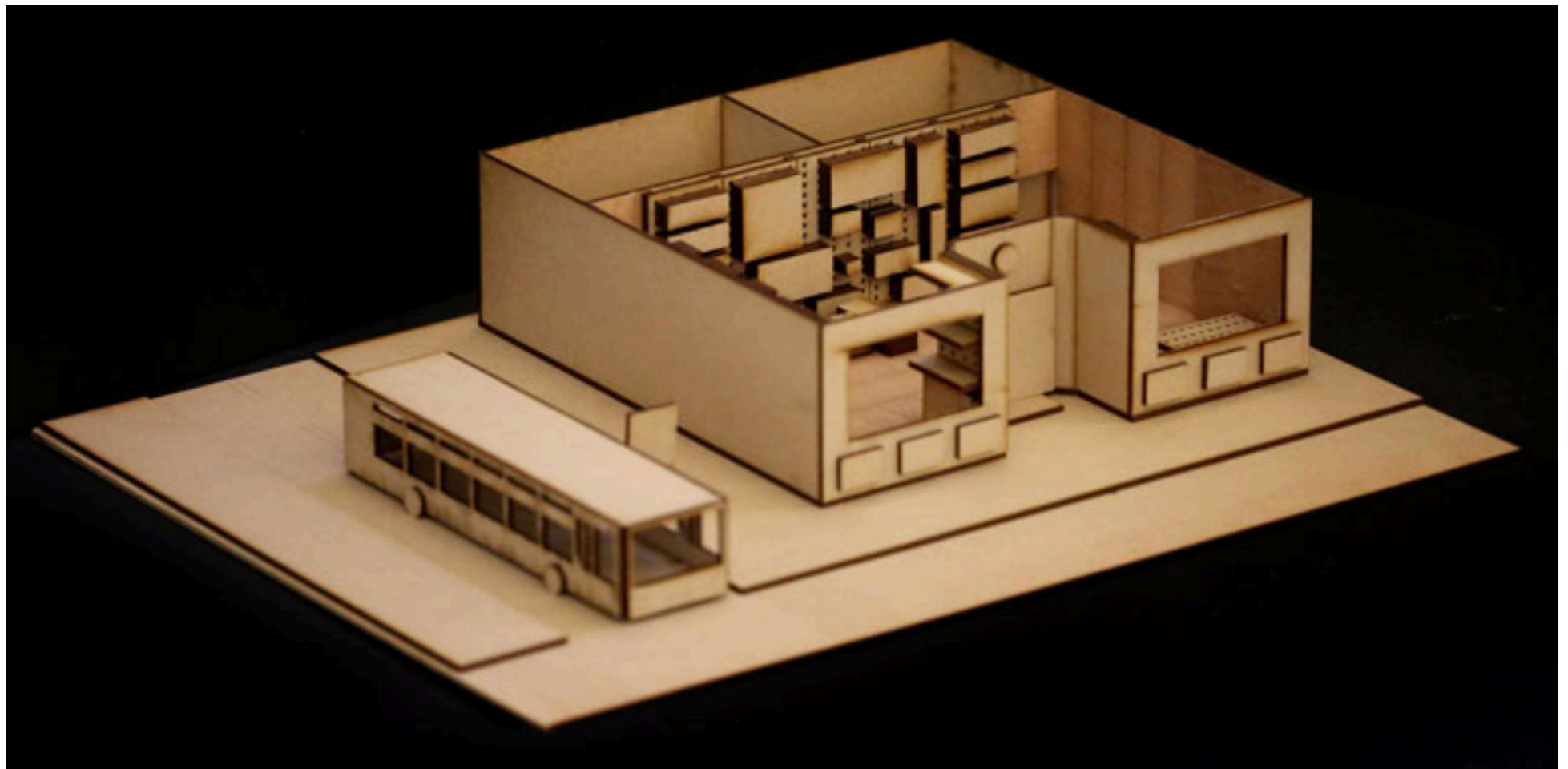
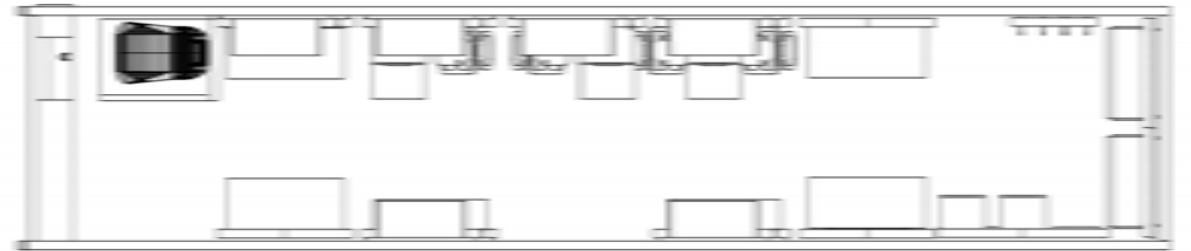
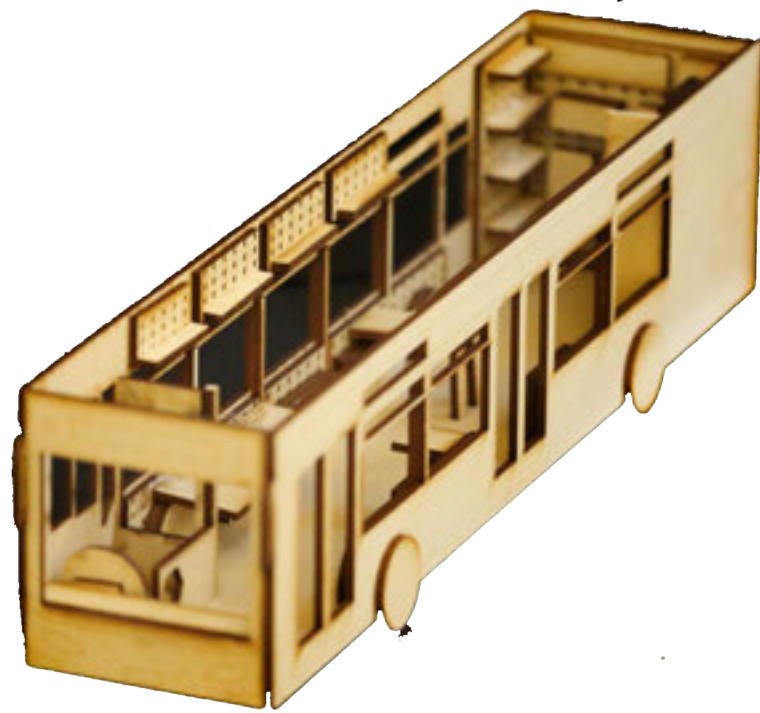



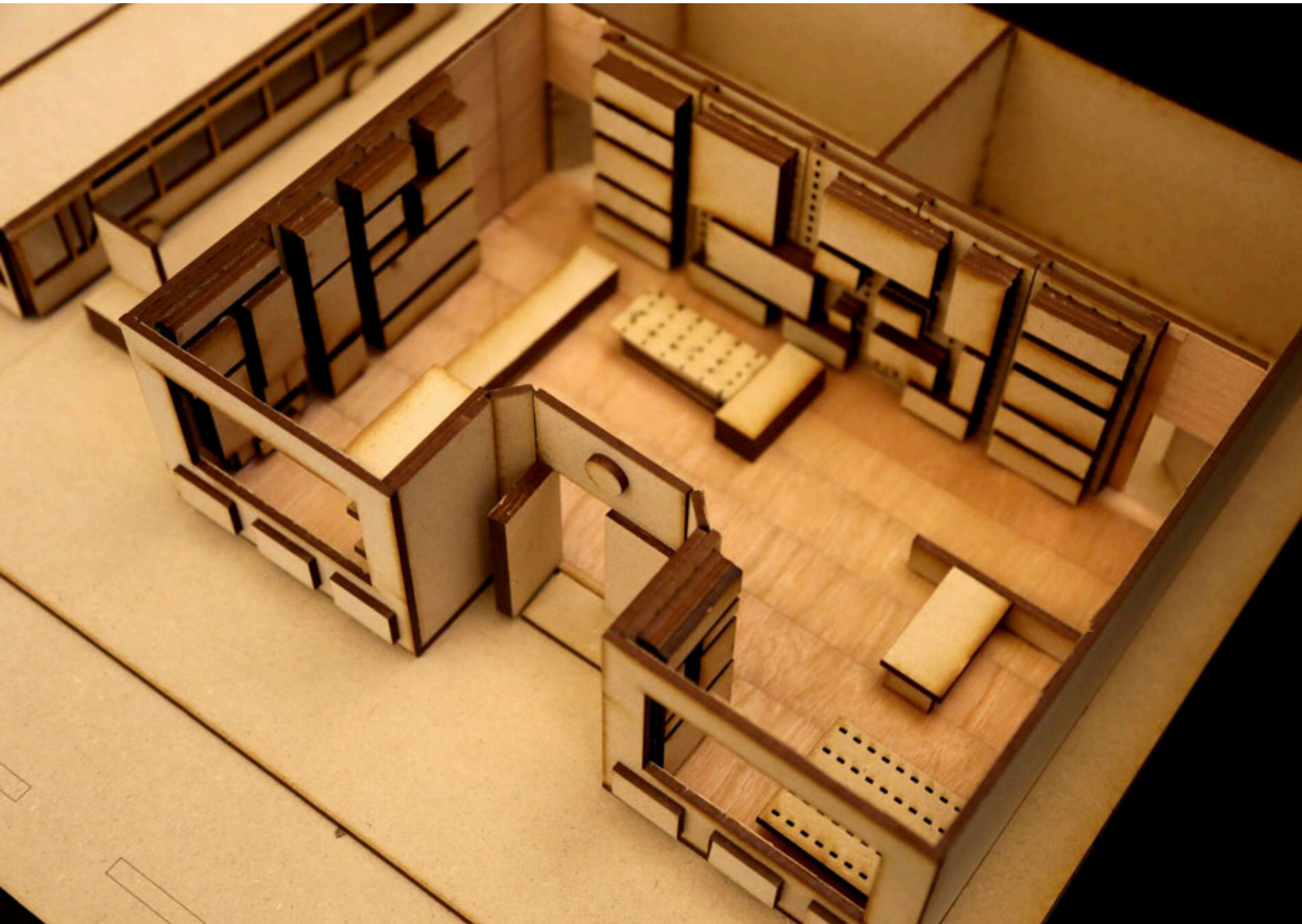

# Public Park & Underground Home

Di Yang  
*Interior Design*

Di is currently a senior interior student at California College of the Arts in San Francisco. She was born in China, she learned how to paint and draw when she was in high school, which gives her a strong fine arts background. After she graduate from high school, she decided to go to United States to get the bachelor degree for interior design. She has great interests in residential and hospitality design.

---

San Francisco is a multicultural city, people are mostly of European, East Asian and Hispanic ancestry, and the European-Americans are in the minority. I want to design a public space for people from different cultures and build underground homes which are right under the park for the homeless to live.

I chose to design a public space because public spaces build relationships and creating communities with people from different cultures, it exposes us to social diversity. Public spaces are

also fundamental features of cities, they represent sites of social ability and face-to-face interaction, and their quality is commonly perceived to be a measure of the quality of urban life. Public spaces also facilitate social inclusion and intercultural communication and present specific socio-spatial practices and processes that transcend ethnocultural divisions and traditional public and private boundaries.

My goal is to gather people from multicultural backgrounds and solving local problems at the same time. The local problem is the homeless in San Francisco. I want to provide homes for the homeless that maximally realizes the land's utility (use both above and underground space for different functions without wasting space). I want to increase communication and interaction between homeless and people from different parts of the world, and provide a sustainable, clean and comfortable shelter for homeless that will also beautify the city.

The location will be the Alamo park on Hayes & Steiner Street in San Francisco. I chose this location because it is right next to the Painted Ladies, which is a famous tourist site, and it also has a large angled terrain slope which allows me to design the underground homes in layers. I want to design the park in the form of a terrace field, so I can follow the topography of the site and create different levels of spaces for people to live.



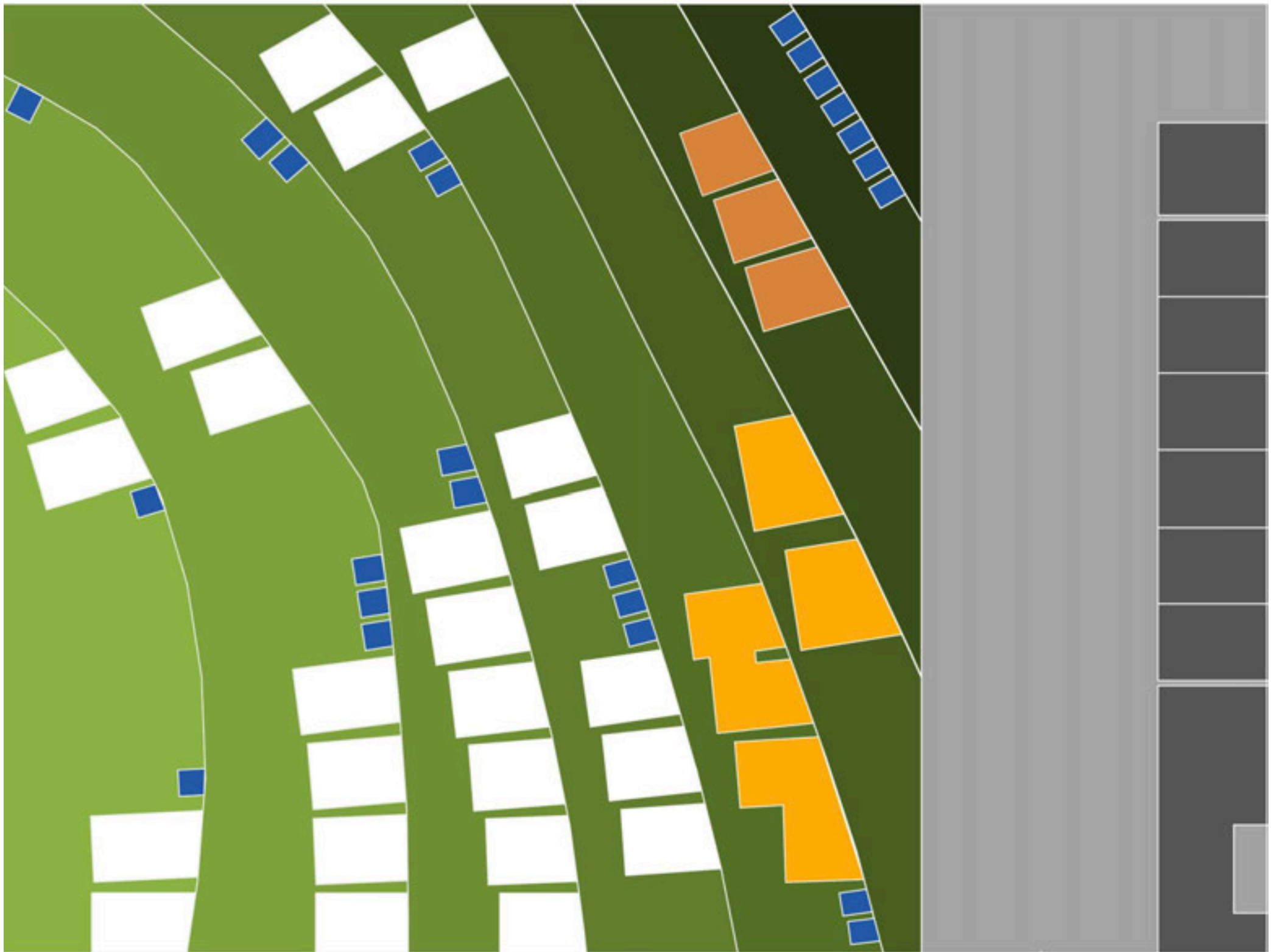

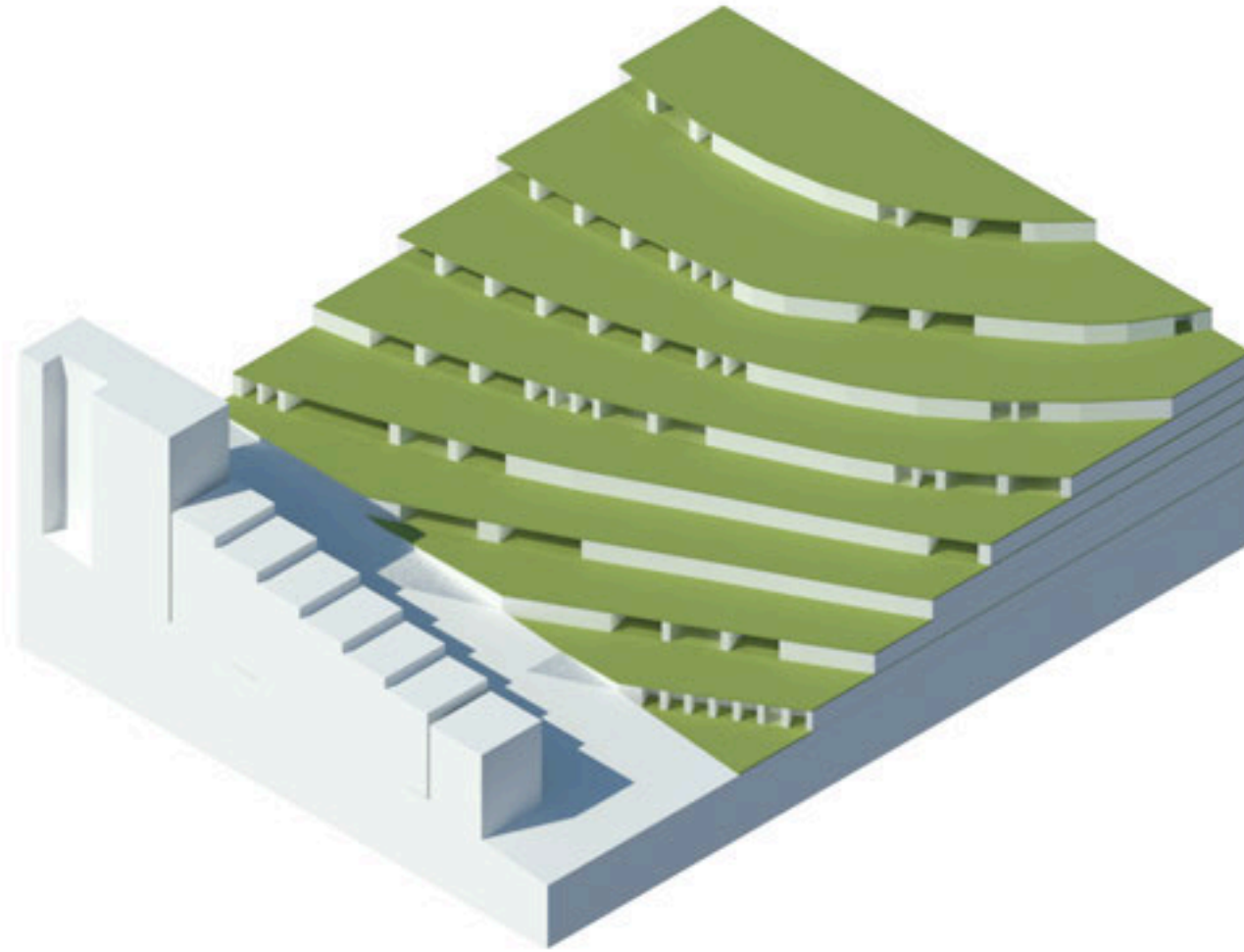

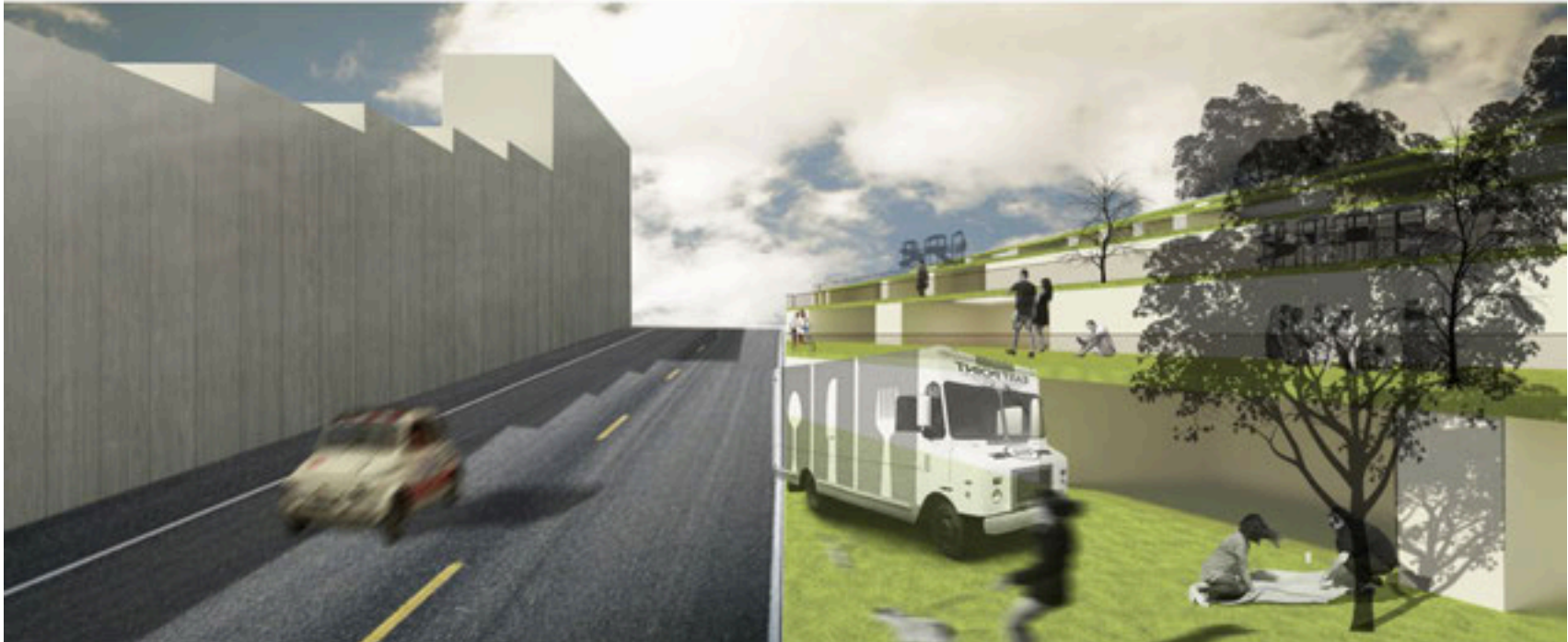

# Linguistic Isolation

Kaiyan Zhao

*Industrial Design & Interaction Design*

Kaiyan Zhao is an international student from China. She is currently a junior majoring in Industrial design and Interaction design, in California College of the Arts, San Francisco. She is interested in human-centered design and she values very much about the design details and how would these details change its interaction with the user. Kaiyan is also passionate about drawing and traveling, to learn different lifestyle and explore the natural world.

---

Through researching and investigating the culture and history of San Francisco, I learned about a serious situation in San Francisco: 35% of the household population who are all immigrants were linguistically isolated, in another words, these people cannot communicate or have social connections outside themselves. They are locked away by their own language, like a jail. Inspired by the artist WeiWei, my personal project will be an installation that expresses the situations and the feelings of the 35% population who are linguistically isolated. In detail, I will make 35 acrylic boxes containing 35 people of different color (yellow, black, white ), meaning linguistic isolation is like a jail that keeps the people separated from the outside. With different color figure, I want people to think about different races. The box will be five white translucent faces and one clear face in different orders, to keep people walking around different angle. On the inner surface of the box, there will be text from different language carve onto the wall, indicating the person was in the box with the only language he or she speaks. The figure would be made of sculpey and there will be tapes covering their mouth, by doing so, I want people to know they can't communicate.











# Istanbul

Marmara University, Faculty of Fine Arts

## Transportation Psychology In The City Life of Istanbul

### Umut Deniz Aktas

*Interior Architecture*

I was born in Istanbul in 1992. I started to my high school career in the painting department. After 4 years education, I graduated from Avni Akyol Fine Arts High School in 2010. After the painting education that I had taken, I started to the department of interior architecture at Marmara University in 2011. I attended various workshops and seminars throughout my university years, I got involved in the National Interior Architecture Meetings. In 2015, I graduated from the department of interior architecture of Marmara University. I continue to work at Naif Design which I've joined in September of 2015. I qualified for master's degree in the department of interior architecture at Marmara University 2016 - 2017 and I currently continue my education.

---

In our daily routine we use mass transport vehicles and get intertwined with so many people. More, we are witnessing how psychological factors affect the people on mass transportation. The subject that I want to study is going to take place on Istanbul subway transportation. We see various people profiles on the subway. We look at the people but don't exactly see who they are and we travel to our destinations. But when we use subway to watch and examine, too many different characters and psychological situations start to appear. If we use these examinations as analysis, we can have ideas about the characters, psychologies and the life styles of the people of our city. I would like to study that subject with visual and statistical aspects. In this context, I am going to show the profiles of the people of Istanbul subway and let all of our friends in this project to do the same examinations in their cities that they live in.



# ISTANBUL KADIKÖY-TAVŞANTEPE

Opening: 17 August 2012

Stations: 19

Travel Time: 38.5 minutes

M4



Line length: 26.5 km

Operating speed: 100 km/h

Passengers Daily  
1.500.000 (approximately)

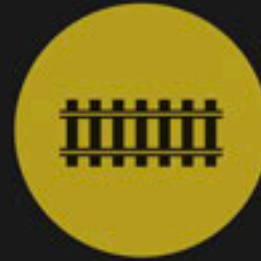

KADIKÖY

AYRILIKÇESMESİ

ACIBADEM

ÜNALAN

GÖZTEPE

YENİSAHRA

KOZYATAĞI

BOSTANCI

KÜÇÜKYALI

MALTEPE

HUZUREVİ

GÜLSUYU

ESENKENT

HASTANE-ADLIYE

SOĞANLIK

KARTAL

YAKACIK

PENDİK

TAVŞANTEPE



IN MY SUBWAY LIFE

MALTEPE

KADIKÖY

▶▶ 20 MINUTES ▶▶



9.00-10.00 AM



6.00-7.00 PM

## SUBWAY PEOPLE



14-25 November

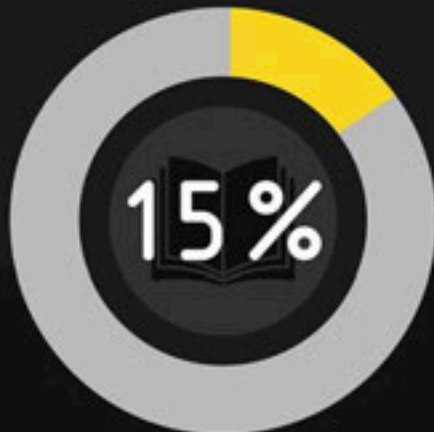

Reading

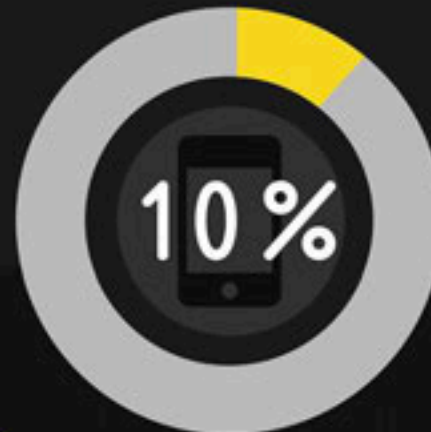

Phone (game)

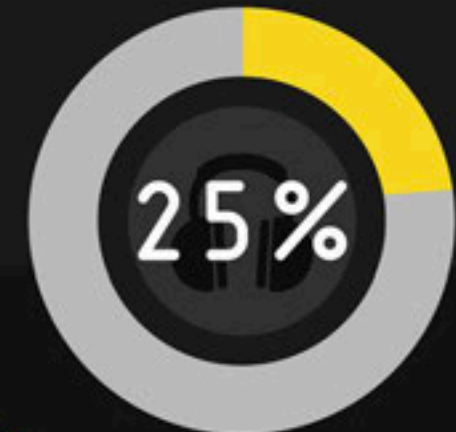

Listening to Music

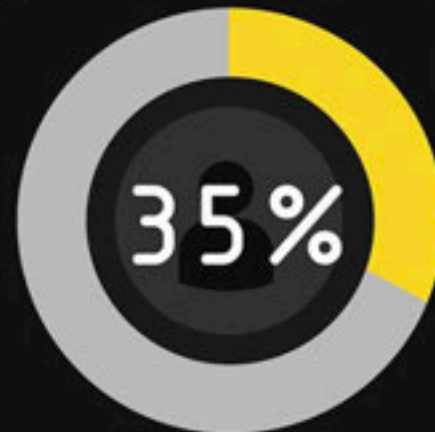

Inactive

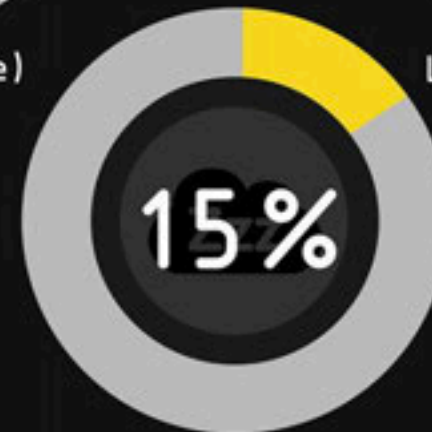

Sleeping

# Contrasts of the Silhouette of the People

**Ogun Canga**

*Interior Design*

Hi! I am Ogün Çanga. I have attended to ISOV Technical High School in 2007-2011. After, I have attended and completed Marmara University Interior Design department with honour and 1st degree in 2015. Then I completed my double major in Industrial Product Design department in 2016. In 2016 I have started Master of Interior Design program at Marmara University I have won several design awards in national design competitions in my university years. In 2015 I joined naftasarım design studio and still continue my career.

---

Thinking, idea and choices are creating the life cycle and the physical appearance of the human. In Istanbul I mostly use the mass transit. Because of my job, observation takes place in every section of my life. These days I observe the human and identity. I see people that are stuck into different silhouettes. Society, ideas and preconceptions shape the human character.

In conclusion of that contrast situations appear. For my subject, I wanted to examine this contrast. For instance, identity from the contrast between the characteristics that we get from our family structure and society. In this context, I want to visualize that contrast via defining every single person as a silhouette.



AYASOFYA MUSEUM



MAIDEN'S TOWER



# Cultural Metamorphosis

## Hazma Demir

*Interior Design*

I am Hazma Demir. I was born in Istanbul in 1990. I graduated from interior design in 2013 with a full scholarship in Istanbul Commerce University. I had participated in many art and design workshops during my studies in Turkey and in several countries in Europe. I have been working as an interior design professional for the last 4 years along with my studies in Marmara University Faculty of Fine Arts for my master's degree in Interior Design.

---

Built in 532 AD, no doubt Hagia Sofia is one of the most iconic buildings in Istanbul. It is famous for having the first greatest dome that collects people under the same "sky". As well as its' magnificent structural features, the main reason for Hagia Sofia to be the center of attraction through centuries, is being a church, a mosque and a museum consecutively. After the Byzantine and the Ottoman periods the secular republic adopted the building and with its' features Hagia Sofia became one of the leading center of multiculturalism.

Central Park is one of the most important landmarks of NYC and it's known for being the first urban park in the world. As it is implied in the name of the park, it is the center of NYC. Millions of tourists from all over the world visit Central Park every year as if it is the United Nations' open-air museum. As Hagia Sofia is the religious public sphere for centuries that gathers people under its dome, Central park is the natural public sphere for the secular world and gathers people under it's sky. In this sense Central Park is the natural center of multiculturalism.

There is an area in Central Park dedicated to John Lennon called Strawberry Fields with an iconic black and white mosaic that refers to his famous song Imagine. Its lyrics encourage the listener to imagine a world at peace without the barriers of borders or the divisions of religion and nationality, and to consider the possibility that the focus of humanity should be living a life unattached to material possessions. We cannot call the shots on the places we were born, the nationalities we belong to and the borders we have to live in whereas our identities are fictional. Just as mentioned in the song I am dreaming a world that people living for today.







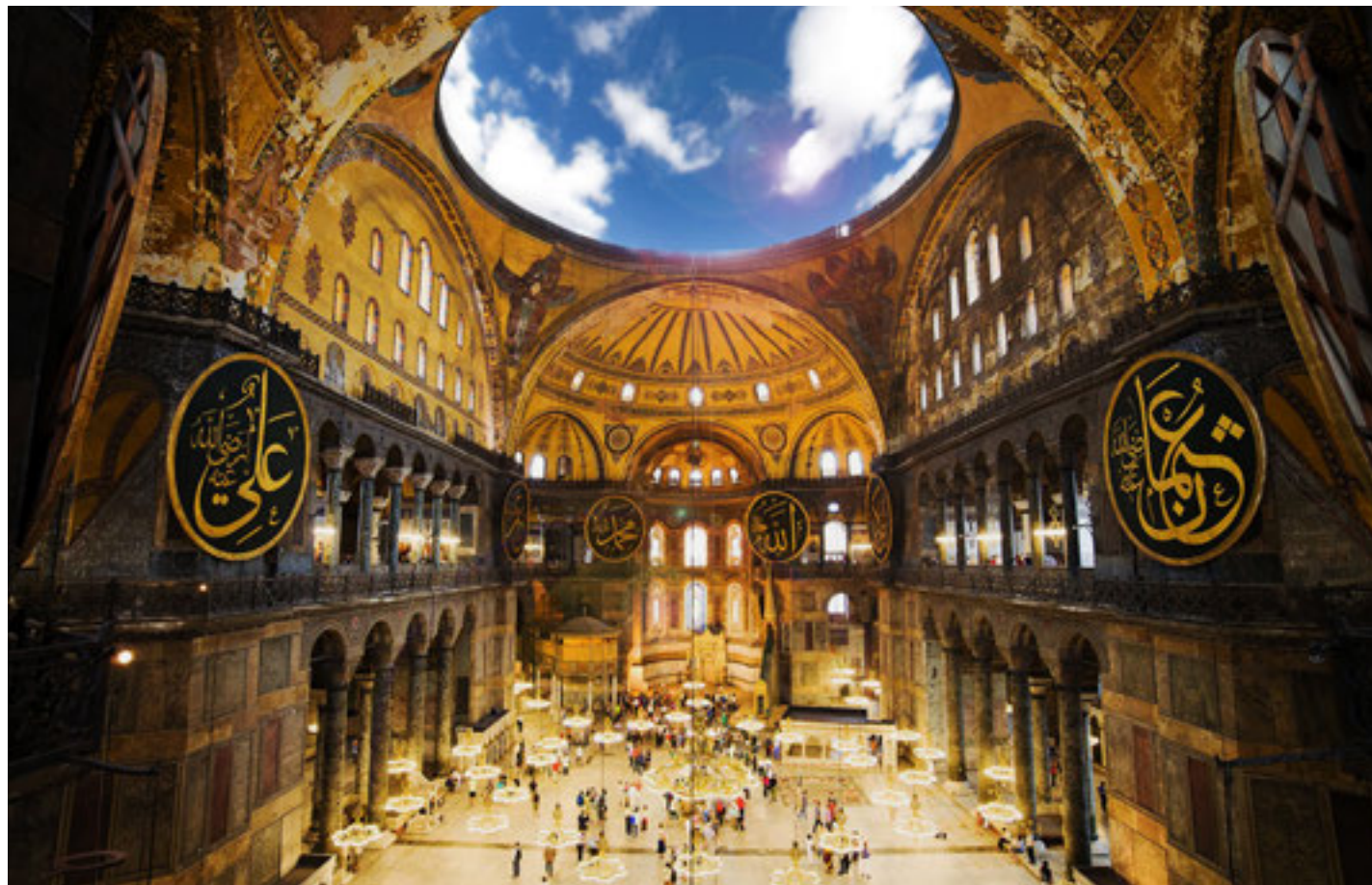

Imagine there's no heaven  
It's easy if you try  
No hell below us  
Above us only sky  
Imagine all the people  
Living for today  
Imagine there's no countries  
It isn't hard to do  
Nothing to kill or die for  
And no religion too  
Imagine all the people living life in peace  
You may say I'm a dreamer  
but I'm not the only one  
I hope some day you'll join us  
and the world will be as one  
Imagine no possessions  
I wonder if you can  
No need for greed or hunger  
a brotherhood of man  
Imagine all the people sharing all the world

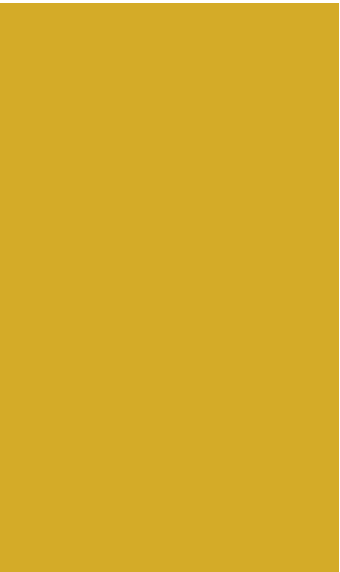

## How Do You Define Your Identity?

### Tahsin Emre

*Interior Design*

Tahsin Emre Eke is a designer with 13 year experience in furniture, product and interior design. He came second in the university matriculation exam in 1997 and completed education with high grade bachelor degree at Marmara University Fine Art Faculty Interior Design Department in Istanbul, Turkey in 2001. He attended some competitions and won thirteen design awards. He completed the Master's program Product Design at Domus Academy Milano in 2013. He has been working as a lecturer at Marmara University Fine Art Faculty Interior Design Department. He is a member of International Designers Association (IATA).

---

Many of the troubles, economic problems, wars that exist in the world, are constituted by the parameters relying upon identity, religion and ideological differences. At this point, it is very important the way we define our identities. I believe, if we go beyond our predefined identities and if we put 'being human' to the center, many of our problems will disappear. I think, there will be peace and increase in the life qualities in a geography where everyone can gather in a single ground without any distinction about their religion, language and ethnicity.

I believe that our project on 'Multiculturalism & Identity' will lead to the emergence of new ideas and thoughts on the interaction of people from different countries. In this context, I want to make a project that we can express the ways we define our identities. That's how we can provide a ground for the participants to be able to question these definitions. In today's technology age, I aim to get a written archive in which too many digital documents are created and also sometimes get lost easily. That way, I like to provide more permanent and more concrete source that one can also feel by hand.

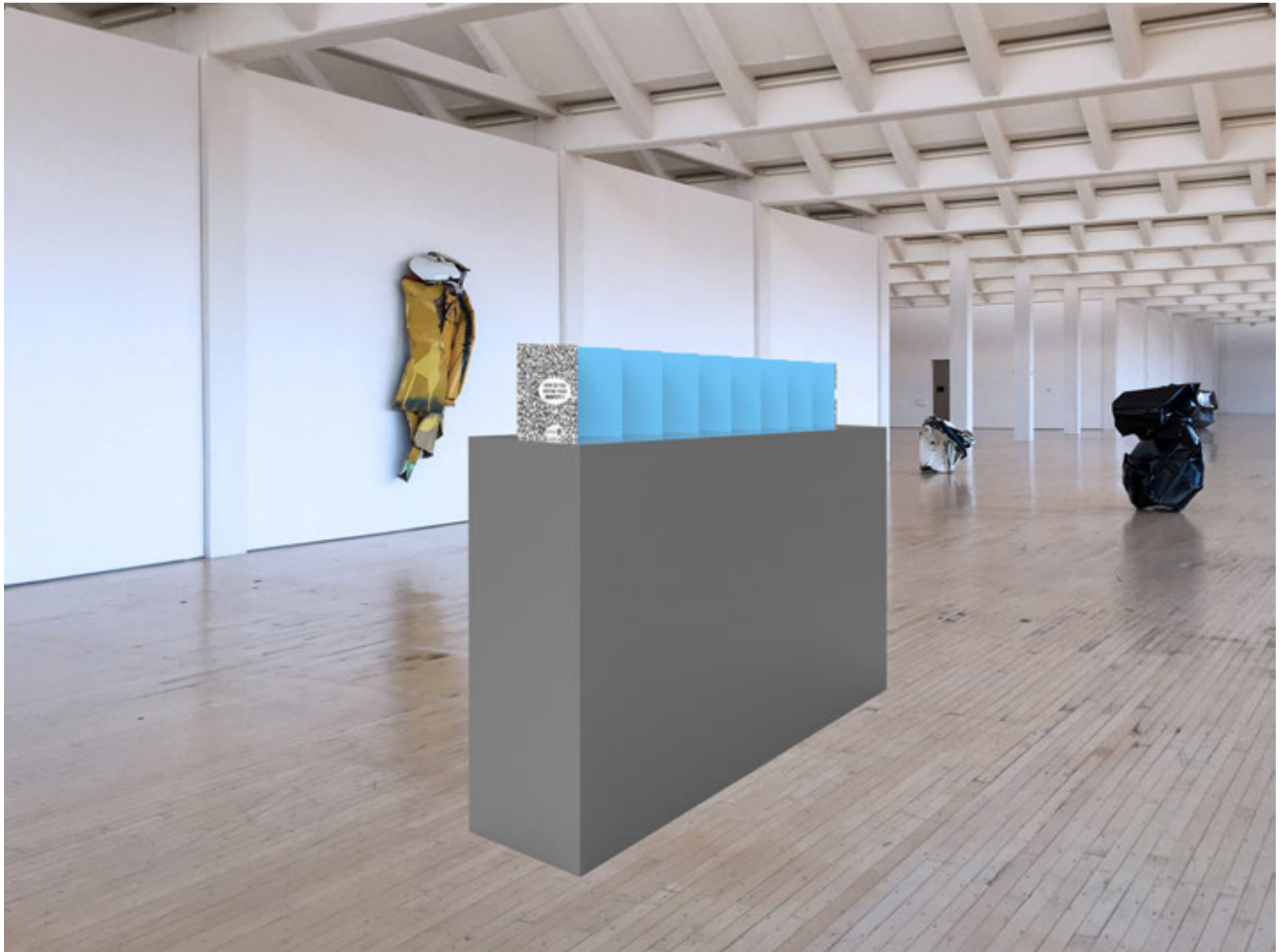

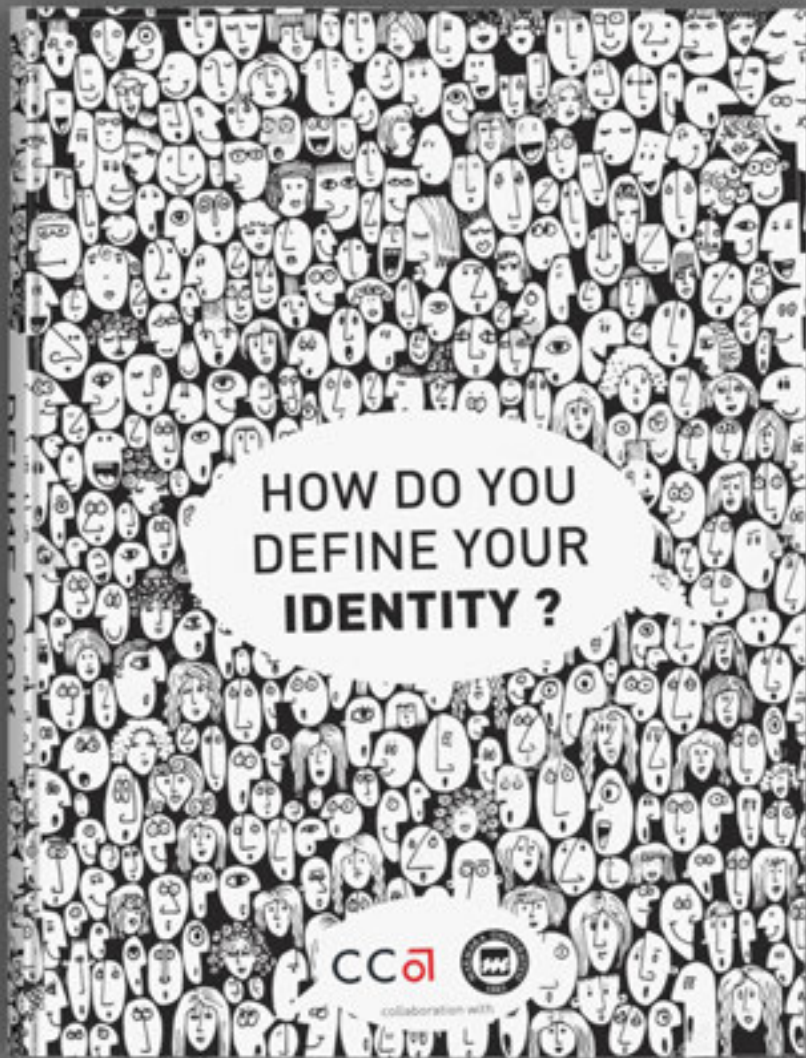

Name : \_\_\_\_\_  
Nationality : \_\_\_\_\_  
Where you live : \_\_\_\_\_  
E-mail : \_\_\_\_\_

WRITE

\_\_\_\_\_

\_\_\_\_\_

\_\_\_\_\_

\_\_\_\_\_

\_\_\_\_\_

\_\_\_\_\_

\_\_\_\_\_

\_\_\_\_\_

\_\_\_\_\_

\_\_\_\_\_

Name : \_\_\_\_\_  
Nationality : \_\_\_\_\_  
Where you live : \_\_\_\_\_  
E-mail : \_\_\_\_\_

WRITE

\_\_\_\_\_

\_\_\_\_\_

\_\_\_\_\_

\_\_\_\_\_

\_\_\_\_\_

\_\_\_\_\_

\_\_\_\_\_

\_\_\_\_\_

\_\_\_\_\_

\_\_\_\_\_

DRAW

Name : \_\_\_\_\_  
Nationality : \_\_\_\_\_  
Where you live : \_\_\_\_\_  
E-mail : \_\_\_\_\_

WRITE

\_\_\_\_\_

\_\_\_\_\_

\_\_\_\_\_

\_\_\_\_\_

\_\_\_\_\_

\_\_\_\_\_

\_\_\_\_\_

\_\_\_\_\_

\_\_\_\_\_

\_\_\_\_\_

DRAW

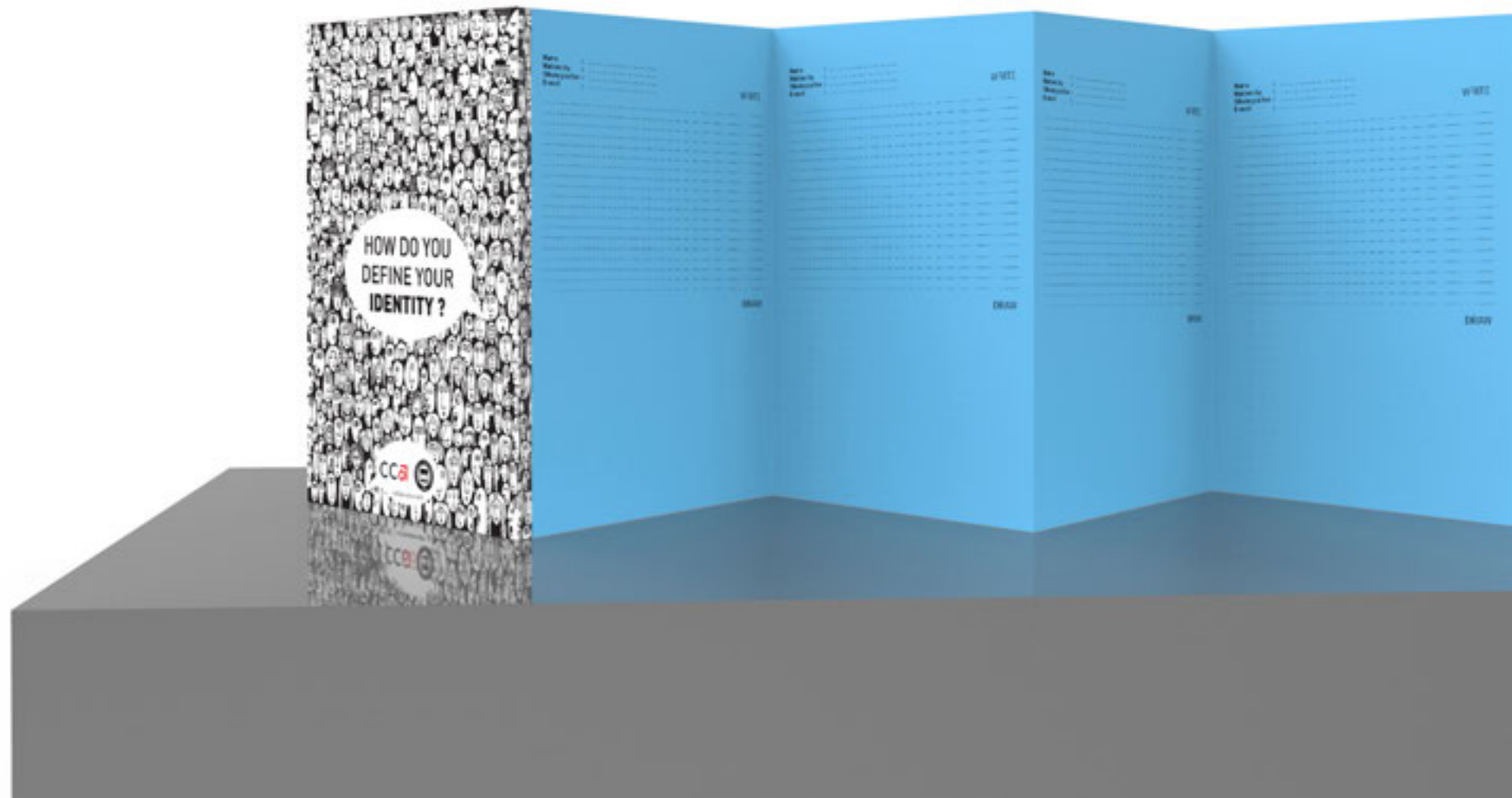

# Religious Buildings of Istanbul

**Bilgehan Ekiz**

*Interior Design*

He was born in Eskişehir, 1988. He graduated from Yeditepe University Interior Design in 2011 and Industrial Design in 2012. He worked with several design studios in Istanbul. Then he attended to Interior Design Master of Arts program at Marmara University. He joined naiftasarim in 2014. He still designs products and spaces at naiftasarim.

Examining how the multiculturalism of the religious beliefs in Istanbul projected to the architecture and city planning of the city.



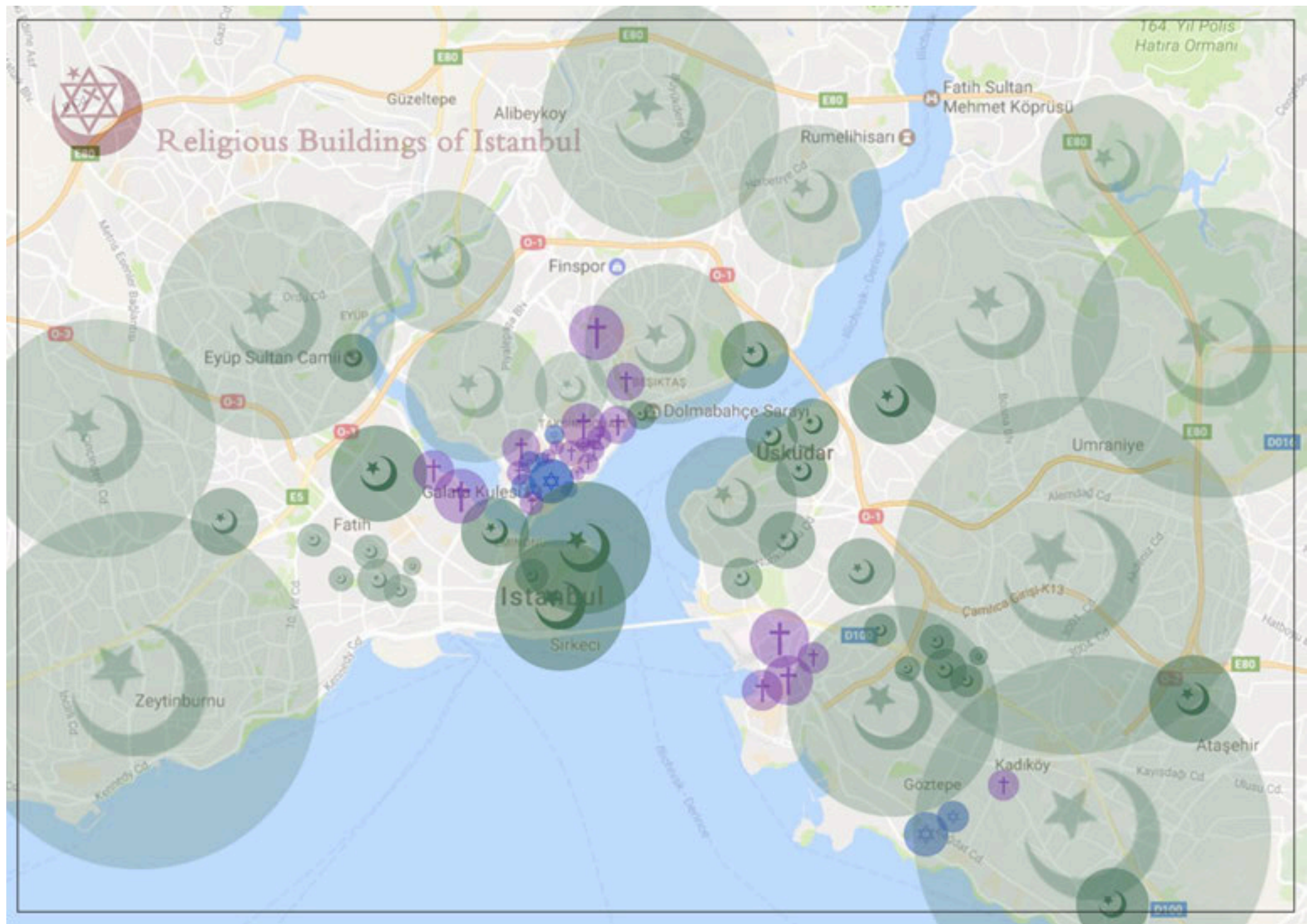

# Jeans

## Aykut Gezersu

*Interior Design*

Aykut Gezersu is an interior designer with 16 years of experience. In 2000, he graduated from Marmara University Fine Arts Faculty Interior Design Department. During his 16 years of professional business life; he designed many places such as home, office, store, restaurant, club or even caravan. One of the most interesting design experiences is the cemetery. The special interest and tendency to painting and sculpture art encourages him to work on these subjects. From 2014 onwards he started to give lessons at Marmara University Faculty of Fine Arts Interior Design Department.

---

Globalisation refers to jobs, people and ideas moving freely and easily around the world. It can also refer to the spreading of ideas, languages, or popular culture between countries. This process is the result of a combination of economic, technological, sociocultural, political and biological factors. Many manufacturing companies today choose to make their products in countries where

the labour costs are low and the conditions are unhealthy. This means they do not have to pay high wages. The products are then sold worldwide enabling huge profits to be made. Blue jeans are a good example of a globalization product. They are also a symbol of a genuine equality and a true democracy that also denies class, male and female distinctions, Jeans worn by male or female, wealthy or poor, all young people, sometimes even by the elderly.

Inhalation dust during this procedure leads to silicosis disease in the lung. Silicosis is not a new disease, but it is a disease that is mainly caused by workers exposed to silica dust in workshops for denim grinding, foundry, tunnels and road construction, ceramics, etc.

The Ministry of Health has banned the use of any substance containing sand, silica dust or silica crystals in the spraying process applied to all kinds of denim clothes and fabrics due to the fact that it causes silicosis, a pulmonary disease that can result in death.



# J E A N S

THE MINISTRY OF HEALTH HAS BANNED THE USE OF ANY SUBSTANCE CONTAINING SAND, SILICA DUST OR SILICA CRYSTALS IN THE SPRAYING PROCESS APPLIED TO ALL KINDS OF DENIM CLOTHES AND FABRICS DUE TO THE FACT THAT IT CAUSES SILICOSIS, A PULMONARY DISEASE THAT CAN RESULT IN DEATH.

DON'T REMAIN INSENSITIVE

T U R N A B L I N D E Y E



j



e



a



n



s



# Istanbul

## Busra Onal

*Interior Design*

Hello. I am Busra Onal. I was born in Istanbul. I graduated with a degree in interior architecture from Marmara University, Faculty of Fine Arts. I did an internship in architecture and furniture design. Now a student in Master's program at Marmara University Fine Art Faculty Interior Design Department.

Istanbul, Turkey's largest city, is one of the world's oldest metropolises with a history of about 2700 years. Located in the center of many civilizations, the city was also called "Constantinopolis" in ancient times. Istanbul, which is built on seven hills, is also known as "Seven-hill city". The Bosphorus passing through the middle; The place of birth in Europe, the continental shelf in Asia, and the two cities that match them all have the property of being the only city with land. The rich history dating back centuries ago is called the "Golden Horn" in particular.

It has different feelings for people with its city streets and street tastes. Knowing and discussing the tastes of the streets of different cities of different cultures can be a way of defining the culture. Istanbul has its own tastes in the neighborhood. Fish and bread, pickles, corn, ice cream semolina, cotton candy, chestnut, mussel, Ottoman paste, meatballs.

In this project, we wanted to show the tastes we could taste in Istanbul streets as much as possible.

I want to combine Istanbul's tranquility with the historical texture of Istanbul and the silhouette of Istanbul that will be hosted by 2700 years of history and many civilizations.



# Istanbul









## Colophon

This catalog was produced for an exhibition at California College of the Arts  
under the direction of S.A.Prof. Mariella Poli in December 2016

Catalog Designed by Ashley Adams,  
Typeset in Adelle Sans (2012).

